

**OPERATION MANUAL
FOR
SENSOR OF O₂ ANALYZER
FOR PROCESSING
TYPE AS-210**

(E) ENERGY SUPPORT CORPORATION

1. General

1-1 Introduction

The PME oxygen analyzer is a very unique analyzer developed through the latest ceramics production technologies. This operation manual describes instructions for the AS-210 type sensor. Refer to the separate operation manual for the analyzer. Read both manuals thoroughly to prolong the service life of our products.

1-2 Precautions

IMPORTANT

- When using the analyzer for the first time after unpacking or after replacing the sensor, the sensor data (linearizer no. and resistance at normal heater temperature , Pressure correction coefficient) must be input and air-point calibration must be preformed.



- Do not handle the analyzer violently and avoid installing it in a location where vibrations may be caused.
- Do not expose the sensor to water or volatile liquids.
- The exhaust and sample gases must not contain corrosive gases.
- If the exhaust and sample gases contain flammable gases, the measured value of oxygen concentration will contain an error.

1-3 Contents

1. General.....	1
1-1 Introduction.....	1
1-2 Precautions.....	1
1-3 Contents.....	2
1-4 Product warranty.....	3
1-5 Outline of product.....	3
1-6 Nomenclature and functions.....	6
2. Installation.....	7
2-1 Installation side.....	7
2-2 How to install sensor.....	8
3. Maintenance.....	10
3-1 How to replace sensor.....	10
3-2 Spare parts list.....	10
3-3 Troubleshooting.....	11

(1) Warranty term

ENERGY SUPPORT CORP. guarantees this analyzer against defective parts and workmanship for one full year from the date of delivery.

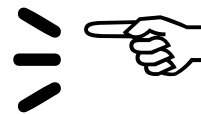

(2) Conditions

ENERGY SUPPORT CORP. will exchange or repair any defective design, parts, or workmanship during the warranty if correctly used, installed and operated at your site provided such defective parts are returned with postage prepaid to the manufacturer or an authorized sales outlet.

Proper operation refers to abiding by the following conditions:

- ① Operation and installation conditions specified in the specifications and this operation manual shall be sufficiently observed.
- ② No excessive mechanical shock or vibration shall be given to the probe generator.
- ③ Periodic calibration of the analyzer and the replacement of consumable parts shall be conducted properly.
- ④ Confirmation of appropriate operation and maintenance shall be conducted properly.

Note: This warranty is not applicable to expendable and consumable parts.

(3) Scope of Warranty

This warranty is limited to the analyzer manufactured and supplied by ENERGY SUPPORT CORP.

The AS-210 type sensor has the following features.

- O₂ analyzer with a zirconia two-cell pump.
- Low power consumption of the sensor (about 13w for normal use)
- Can be calibrated using air (requires only span point calibration and no zero calibration)
- Short warm-up time (about 3 minutes)
- Easy maintenance
- Compact design



Theory of oxygen analyzer with zirconia two-cell pump

1. Configuration and function (refer to the figure on the right)

① Heater

The zirconia element is heated to approximately 800°C.

② Sensing cell

(1) Sets the oxygen concentration of the reference oxygen chamber to approximately 100%.

(2) Measures the oxygen concentration of the gas detection chamber.

(For details on the theory, refer to the following description.)

③ Pumping cell

Sets the oxygen concentration of the gas detection chamber to 0%.

(For details on the theory, refer to the following description.)

④ Gas detection chamber

Incorporates the sample gas through the gas diffusion holes.

⑤ Reference oxygen chamber

Always kept at about 100% O₂ by reference oxygen micro current.

2. Features of zirconia element caused by being heated at high temperature

① When gases with different oxygen concentrations are placed between the electrodes, the oxygen ionic conduction occurs, generating an electromotive force.

(Oxygen concentration cell theory)

② By passing the electric current between the electrodes, the oxygen ions move in the opposite direction of the electric current. (Oxygen pumping theory)

The sensing cell uses features ① and ② and the pumping cell ②.

3. Theory of sensing cell

① Micro current is passed between the electrodes of the sensing cell. By passing the electric current between the electrodes, the oxygen ions in the gas detection chamber move to the reference oxygen chamber so that the oxygen concentration of the reference oxygen chamber becomes about 100% O₂.

(Note) The number of the O₂ ions that move from the gas detection chamber to the reference oxygen chamber is extremely small so it has no effect on the oxygen concentration in the gas detection chamber.

② Between the electrodes of the sensing cell, an electromotive force is generated due to the difference in the oxygen concentrations of the gas detection chamber and the reference oxygen chamber. It can be calculated from the following equation.

The sensing cell measures this electromotive force generated between the electrodes and sends signals to the pumping cell so that the electromotive force will be 350mV (i. e. so that the oxygen concentration in the gas detection chamber will be 0% O₂).

Electromotive force $E =$

$$\text{approx. } -53.2 \times \log_{10} \frac{\text{Oxygen concentration in gas detection chamber (sample gas concentration)}}{\text{Oxygen concentration in reference oxygen chamber (100)}}$$

$$450 = -53.2 \times \log_{10} \frac{X}{100}$$

$$X = \text{approx. } 0.003\text{ppm} \doteq 0\%$$

4. Theory of pumping cell

The pumping cell receives signals from the sensing cell and passes electric current between the electrodes so that the oxygen concentration in the gas detection chamber becomes 0% O₂.

Since the electric current is proportional to the number of O₂ ions (oxygen concentration) discharged from the gas detection chamber, the oxygen concentration of the sample gas (i.e. oxygen in the gas detection chamber) can be measured by measuring the electric current.

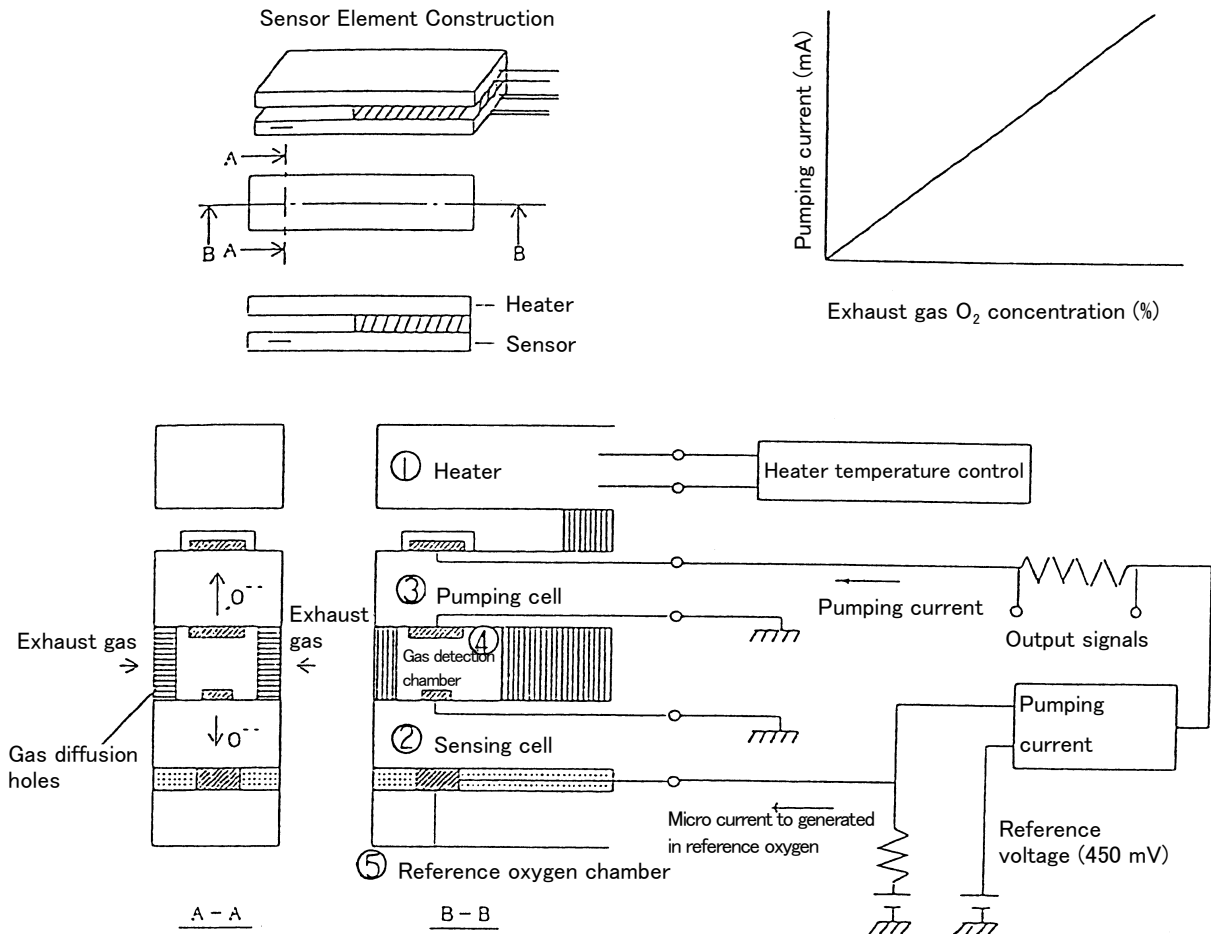

1-6 Nomenclature and functions

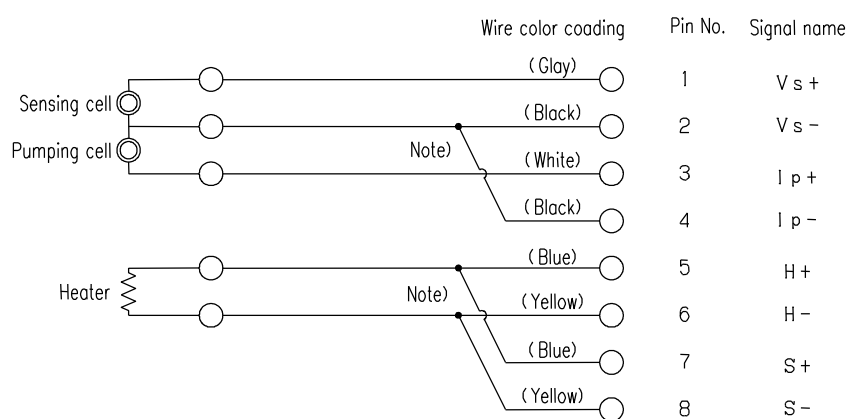
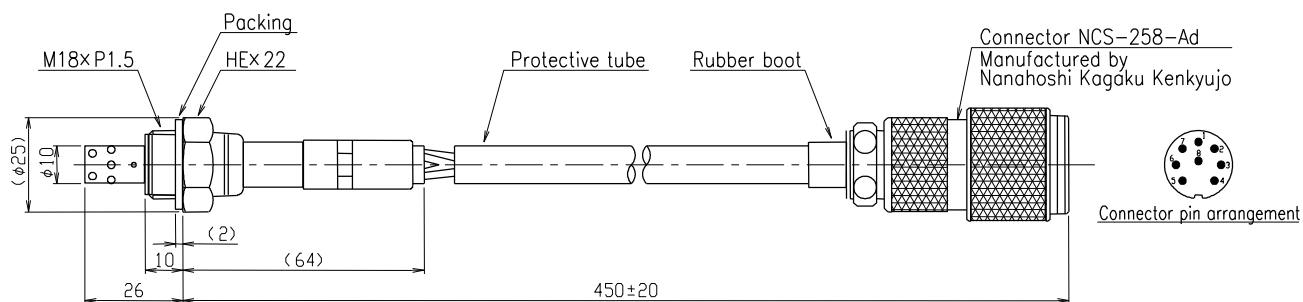

2. Installation

2-1 Installation side

IMPORTANT

- Avoid exposure to rain, water, and oil.
(This sensor is not designed for outdoor use. When using it outdoors, a protective cover shall be provided.)
- Avoid direct sunlight or radiated heat from furnace. The ambient temperature of the metal connector of the sensor shall not exceed 120°C.
- Select a place with little humidity and dust.
- Vibrations shall be transmitted as little as possible.
- The central value of the gas to be measured shall be obtained.
- Condensation occurs at the sensor mounting section depending on the sample gas condition and ambient environment, resulting in the damage of the sensor. If there is a fear of condensation, insulate the mounting adapter, pipes, etc.
- The condensation adhered to the sensor will cause the sensor to be faulty. Make sure that there will be no condensation around the sensor.
- The air ratio of the gas to be measured must be 0.65 or more. If the measuring gas contains an air ratio of 0.65 or less, or a large amount of CO and/or H₂, this may cause the sensor to break in a short time. Do not expose the sensor to the gas with high reduction ability.
- If the sensor is used in the sampling system (the measuring gas is sampled to the outside of the furnace and measured after the drain is removed), where flammable gas, such as CO or H₂ exists, measure the gas after performing the water bubbling at room temperature and humidification.

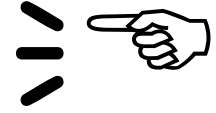

2-2 How to install sensor

Consult Engineering service of ENERGY SUPPORT if you use unspecified mounting methods or you have any questions.

(1) When installing the sensor directly on the flue

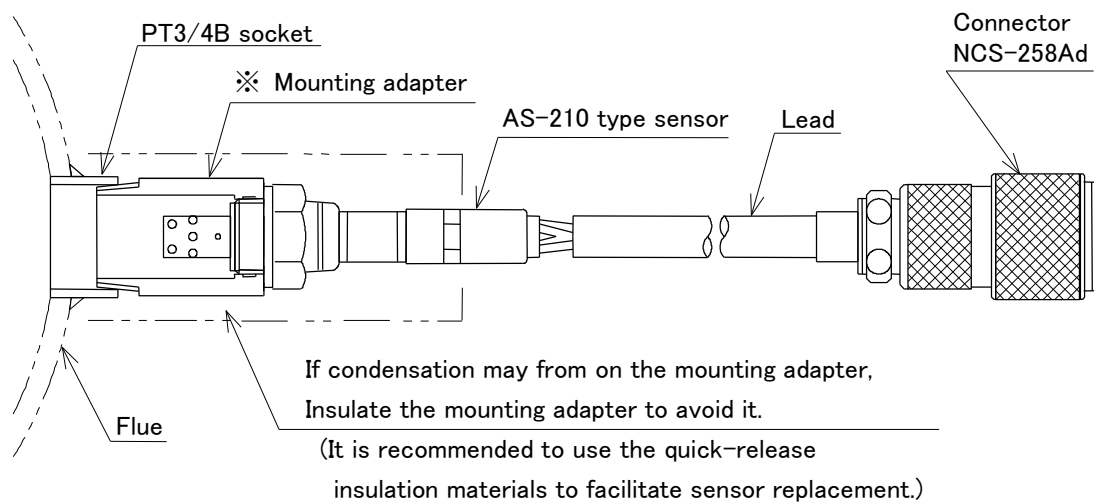

(2) When taking the gas from the exhaust path in the flue

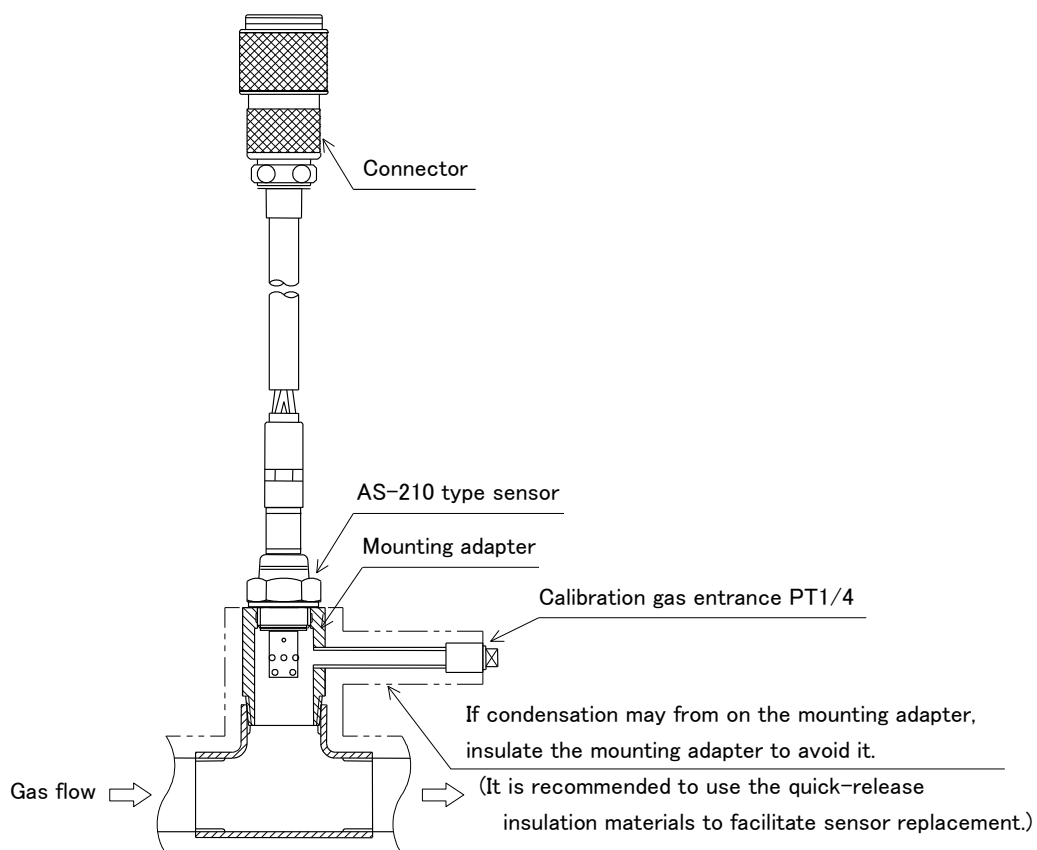

(3) When exhaust gas is sampled and measured;

Various mounting methods are provided depending on the usage. It is the precondition that drain is not mixed in the sampling gas.

This sensor element is the ceramics heated to approx. 800°C. The sensor is damaged if drain is splashed on the sensor. If there is any fear of mixing of the drain, take measures to prevent mixing and select the proper mounting method so that the sensor tip is not directly located at the flow of the measured gas as shown in the figure below.

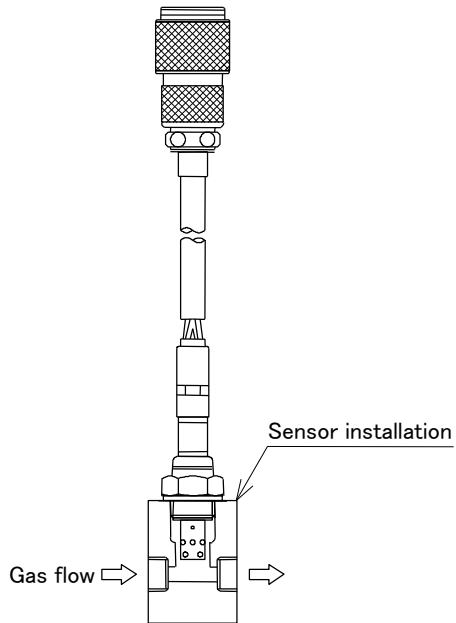

3. Maintenance

3-1 How to replace sensor

- ① Turn OFF the main power of the analyzer.
- ② Remove the connector.
- ③ Remove the hexagonal part of the sensor by turning it counterclockwise with a monkey wrench.
- ④ Replace the sensor with a new AS-210 type sensor.
- ⑤ Tighten the hexagonal part of the sensor by turning it clockwise with a monkey wrench.

(Note)

The tightening pressure shall be 0.2 ± 0.1 kgf.m. Tightening it more than that will deform the packing.

When the mounting adapter is hot (200°C or higher), use a metal packing.

The tightening pressure shall be 4 ± 0.5 kgf.m.

- ⑥ Mount the connector.
- ⑦ Turn On the main power of the analyzer.
- ⑧ Wait about three minutes. Then enter the date of the new sensor through the keys.

Input items	Input location for receiver		
	RE-210	DTF-201R	DTF-101
Linearizer no.	CH2	CH143	SENSOR PARAMETER 「LIN」
Heater resistance ※1	CH10	CH192	DISPLAY SELECT 「RHO」
Pressure correction coefficient ※2	—	—	PRESSURE SET 「β 1」

The date is described in the inspection sheet.

※1 : When the end of the Re-210 type receiver product number is D,
CH10 Heater resistance input is unnecessary.

(Receiver product number KX-621020-***D)

※2 : input Only KX-721045-B-*

- ⑨ Perform air point calibration.
- ⑩ The sensor is ready for measurement.

3-2 Spare parts list

Part name	Part no.	Remarks
Sensor	KX-721045-B(-*)	
Connecting cable	KX-821100-L	
Connector	NCS-258-P	Connector on the cable end
Packing	RX-331300-11	

3-3 Troubleshooting

- ① When the mounting adapter or pipes are clogged
 - Remove the dust clogging it using a piece of wire or a rod.
- ② When the sensor becomes faulty due to adhered condensations
 - Heat and insulate the mounting adapter up to about 200°C using a heater or the like.
- ③ When the indicated value is high
 - Check the screw section or packing of the mounting adapter to see if there is a leak.
 - Check if dust is clogging the adapter or pipe.

The contents of this manual are subject to change without notice for improvement.



For inquiries regarding product handling, please contact us or our distributors.
Inquiry form URL : <https://www.energyys.co.jp/english/inq/all.php>
ENERGY SUPPORT CORPORATION
1, Aza Kamikobarii, Inuyama, Aichi 484-8505 Japan

