

Operation Manual for
TF-10
Oxygen Analyzer
(Probe Transmitter)



The person who operates the product must read through this instruction manual.

(E) ENERGY SUPPORT CORPORATION

Safety precautions



WARNING

- (1) A voltage of 85 – 132V AC is applied to the power supply terminal of the receiver. Before checking the wiring, always turn OFF the power. Failure to do so may cause an electrical shock.
- (2) To prevent electrical shock hazards, always ground the grounding terminals firmly.
- (3) If the sensor unit is removed while the plant is being operated, the hot sample gas may spout out from the furnace. Therefore, do not remove the sensor unit during operation. If removal of the sensor unit is absolutely required, always observe the following cautions.



CAUTION

- (1) Carefully observe the following cautions when installing or removing the probe transmitter.
 - ① Always wear heat-resistant gloves since parts close to the mounting seat are hot.
 - ② The hot sample gas and/or soot and dust may spout out from the opening of the mounting seat. Do not get access to the opening.
 - ③ The gas may also spout out from the calibration gas piping ports. Before installing or removing the probe transmitter, attach stop plugs to the piping ports. Restore the piping to its previous state immediately after the probe transmitter has been installed.
 - ④ The probe transmitter and sensor unit are hot. Always wear heat-resistant gloves to prevent burning hazards.
- (2) The probe transmitter must be installed while the plant is stopped. Turn ON the probe transmitter one hour before starting the plant operation to raise its temperature.

If the temperature of the transmitter is not raised to its specified level, the sensor may be damaged by the corrosive gas, causing the sensor to deteriorate earlier than usual.
- (3) Always carefully install and/or remove the probe transmitter and sensor unit. Failure to do so may cause the ceramic parts inside the unit to break.
- (4) Do not turn the terminal block with the sensor unit secured. The lead wires inside the sensor may be twisted, resulting in faulty wiring.

1. General description

1.1 Introduction

“Model TF Zirconia Type O₂ Analyzer “ is a unique oxygen analyzer emerged out of the state-of-art fine ceramics technology. Down-sizing, minimal power consumption were attained with the integration of zirconia sensor and the ceramic heater. This Instruction Manual described the installation, operation and inspection procedures of Model TF-10 for Model TF Zirconia Type O₂ Analyzer. We hope that this unit is operated after reading this Operating Manual carefully prior to using it understanding the details of it thoroughly.

1.2 Product guarantee

- (1) Term: Described in the final document.
Unless it is provided, the warranty term will last for one year after acceptance.
- (2) Conditions: In the assumption that the product is properly stored and installed till the test operation and adjustment after acceptance at the customer's site, the delivered product shall be replaced or repaired without charge if any trouble or abnormality attributed to the poor design, manufacture or material which our company is responsible for occurs though the product is properly used during the above warranty term. Here, the proper operation method is as follows:
- ① The operational conditions and installation conditions described in the specifications and instruction manual shall be satisfied.
 - ② Any excessive mechanical shock or vibration shall not be applied to the probe transmitter.
 - ③ Calibration of the analyzer and replacement of the consumable parts shall be periodically carried out.
 - ④ The operational state of the analyzer shall be checked and maintained.
- (Note) The consumable and similar parts shall be outside the warranty range.
- (3) Application: The warranty shall be limited only to those article delivered by us.
Warranty shall not be applicable to the losses incurred following to the failure of our delivered articles(the losses or lost profits and others incurred out of the controls or records by using the articles delivered from us, the losses or lost profit and others of the equipment on which the articles delivered from us are installed).

1.3 Table of contents

1. General description	2
1.1 Introduction	2
1.2 Product guarantee	2
1.3 Table of contents	3
1.4 General cautions	4
1.5 Outline of product and measuring principle	5
1.6 Part names and functions	8
2. After unpacking of unit	12
2.1 Checking of accessories	12
2.2 Temporary storage of product	13
3. Installation	14
3.1 Installation conditions	14
3.2 Installation procedures	15
3.3 Piping and wiring procedures	20
3.4 Inspection after installation	23
4. Maintenance	25
4.1 Cautions for maintenance	25
4.2 Maintenance and inspection items	26
4.3 Troubleshooting	27
4.4 Replacement parts	28
4.5 Replacement of parts	29
5. References	35
5.1 Standard specifications	35

Request and information sheet to ENERGY SUPPORT CORP

1.4 General cautions 

- Always carefully install and/or remove the TF-10 probe transmitter and sensor unit. Failure to do so may cause the ceramic parts inside the unit to break.
- The following table shows the requirements for operating environment.

Probe transmitter	Installation place	Indoor/outdoor
	Ambient temperature (°C)	-10 – 80
	Ambient humidity (% RH)	90 or less
	Installation posture	Horizontal – vertical downward

* The ambient temperature of the pump air type unit is 0 - 40°C.

- If any corrosive gas and/or organic gas not stated in the specification are included in the operating environment, this may shorten the service life of the sensor.
- The number of installation flange vibrations shall be 100 Hz or less and the vibration amplitude shall be 0.5G or less.
(The vibration amplitude shall be 0.2G or less if the probe length is 1500 mm or 1000 mm and the horizontal mounting with the guide pipe is used.)
- If the unit is installed in a place where the vibration level of the installation flange exceeds the above level, the customer must take appropriate measures so that the vibration is not applied to the probe transmitter directly.
- The probe transmitter is vulnerable to thermal shock. Do not place the hot probe transmitter on the cold floor directly.

1.5 Outline of product

This product provides the excellent features listed below.

- No standard gas bombs are required.

Theoretically, there are no zero-drifts. The zero gas calibration, as well as maintenance of the standard gas bomb are not required.

- No reference air is required.

Since the reference air is self-produced inside the sensor, no reference air is required. Additionally, since a pump is built-into the calibration unit, no calibration air source is required.

- Built-in automatic calibration requires no daily maintenance work.

Automatic calibration with the internal cycle timer is built-into the product as standard accessory. One-push manual calibration is also possible.

- Less expensive construction cost

Only 100V AC power supply is required as utility. No instrument and factory air sources are required.

Additionally, no special electric wires (thermocouple compensation conductors) are required. Only two 4-core cables and one calibration air piping are required, ensuring less expensive construction cost.

- Low power consumption

The power consumption is approximately 40W, ensuring economical system. Additionally, the unit becomes ready for measurement only 3 min. after the power has been turned ON.

- Small diameter, and compact and light weight design

A thick film sensor integrating the zirconia sensor and ceramic heater is assembled into the pipe with a diameter of 10 mm. This makes it possible to install the unit even though the insertion port is small (ϕ 21.7 or more).

If the insertion length is 500 mm, the weight of the sensor unit is approximately 1 kg and that of the probe transmitter is approximately 2.5 kg. This lightweight design ensures easy installation of this unit in a small boiler.

Principle of Zirconia 2 Cell Pump Type Oxygen Analyzer

1. Construction and functions (Refer to figure at right)

- ① Heater : Sensing element is heated to approx. 800°C
- ② Sensing Cell :
 - (1) Set the oxygen concentration of reference oxygen chamber to approx. 100%.
 - (2) Measure the oxygen concentration of gas detection chamber.(Refer to the following for detailed theory of operation.)
- ③ Pumping Cell : Set the oxygen concentration of gas detection chamber to 0%.
(Refer to the following for detailed theory of operation.)
- ④ Gas Detection Chamber : Gather the exhaust gas through the gas diffusion holes.
- ⑤ Reference Oxygen Chamber : The oxygen concentration is at approx. 100% with the reference oxygen electrical micro current.

2. Characteristics of the detection section when heated to a high temperature.

- ① An electromotive force (EMF) is generated with an induced oxygen ion conduction when gasses of different oxygen concentration are placed between the electrodes.
(Oxygen Battery by Concentration Principle)
- ② By flowing an electrical current through the electrodes, oxygen ions proportional to such a current are transferred in the opposite direction to the electrical current.
(Oxygen Pumping Effect)

The sensing cell utilizes principles ① and ②, while the pumping cell utilizes principle ②.

3. Principle of the sensing cell

- ① A minute electrical current flow is applied between the electrodes of the sensing cell.
By flowing electrical current through the electrodes, oxygen in the gas detection chamber is transferred to the reference oxygen chamber becomes approximately 100%.

NOTE : As the amount of oxygen transferred from gas detection chamber to the reference oxygen chamber is extremely small, the oxygen concentration in the gas detection chamber is not affected.

- ② An electromotive force determined by the equation shown below is generated between the electrodes of the sensing cell owing to the difference in oxygen concentrations between gas detection and reference oxygen chambers.

This electromotive force is measured in the sensing cell section and sends a signal to the pumping cell so that this electromotive force will become 450mV (oxygen concentration in the gas detection chamber is 0%).

$$\text{EMF} = \text{About } -53.2 \times \text{Log}_{10} \frac{\text{Oxygen Concentration in Gas Detection Chamber}}{\text{Oxygen Concentration in Reference Oxygen Chamber (100)}}$$

$$450 = -53.2 \times \text{Log}_{10} \frac{X}{100}$$
$$X = 0.00348\text{ppm} \doteq 0\%$$

4. Principle of the pumping cell

An electrical current is applied between the electrodes of the pumping cell so that the oxygen concentration of the gas detection chamber becomes 0% by receiving a signal from the sensing cell.

Because the oxygen concentration in the exhaust gas is proportional to the electrical current that flowed, the oxygen concentration in the exhaust gas can be measured by measuring the electrical current.

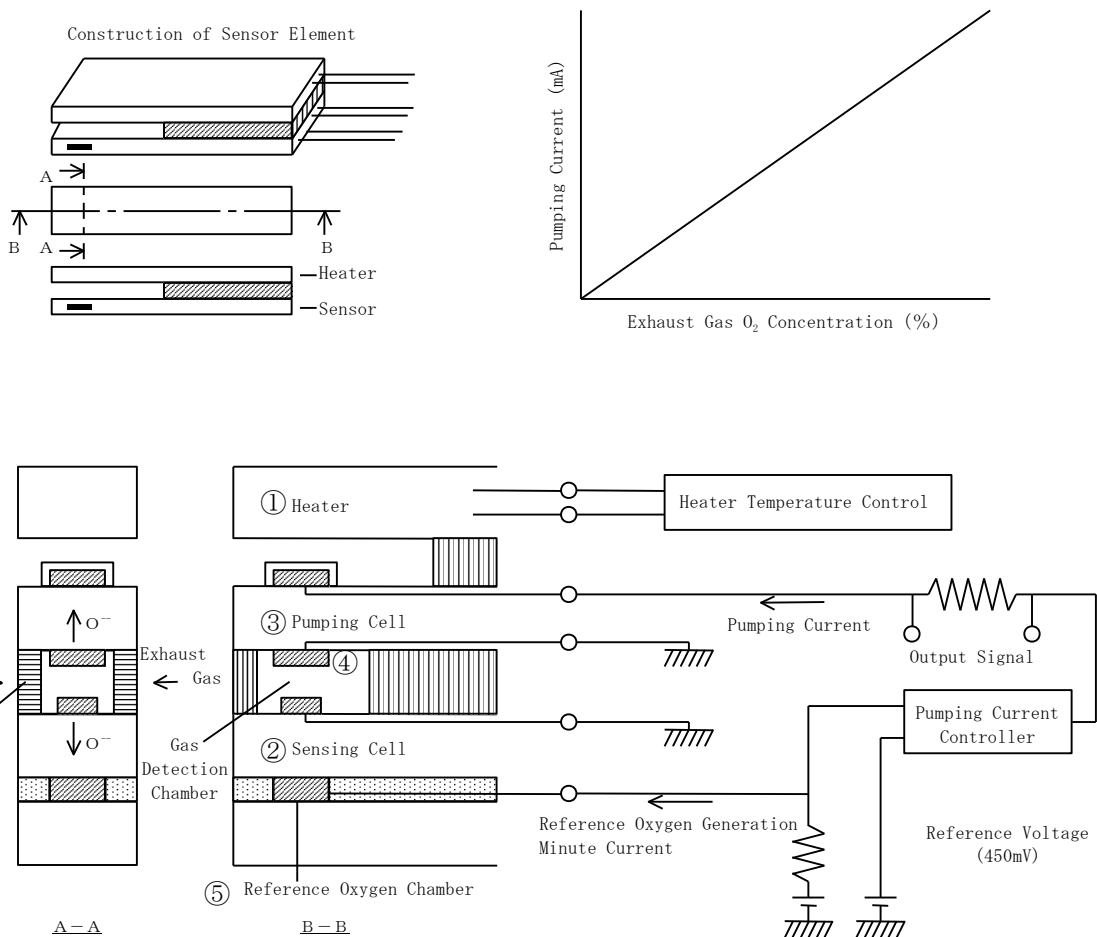

1.6 Part names and functions

TF-10 probe transmitter
KX-331022-A**(-*)

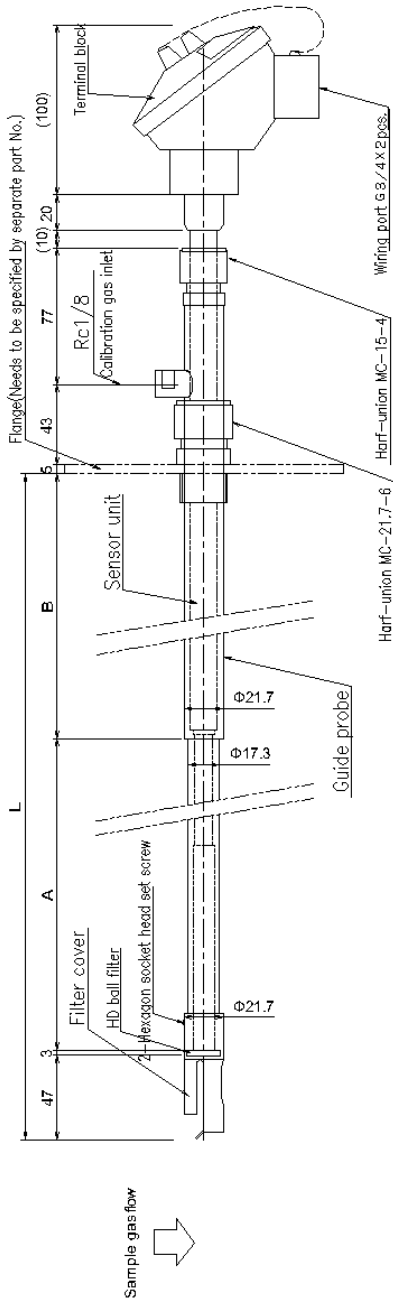

TF-10 probe transmitter
KX-331023-A**(-*)

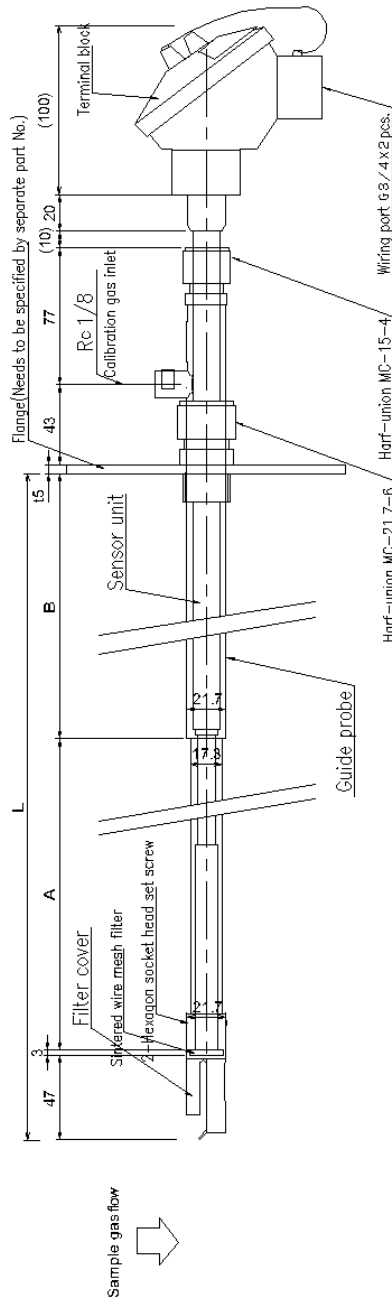

Standard flange

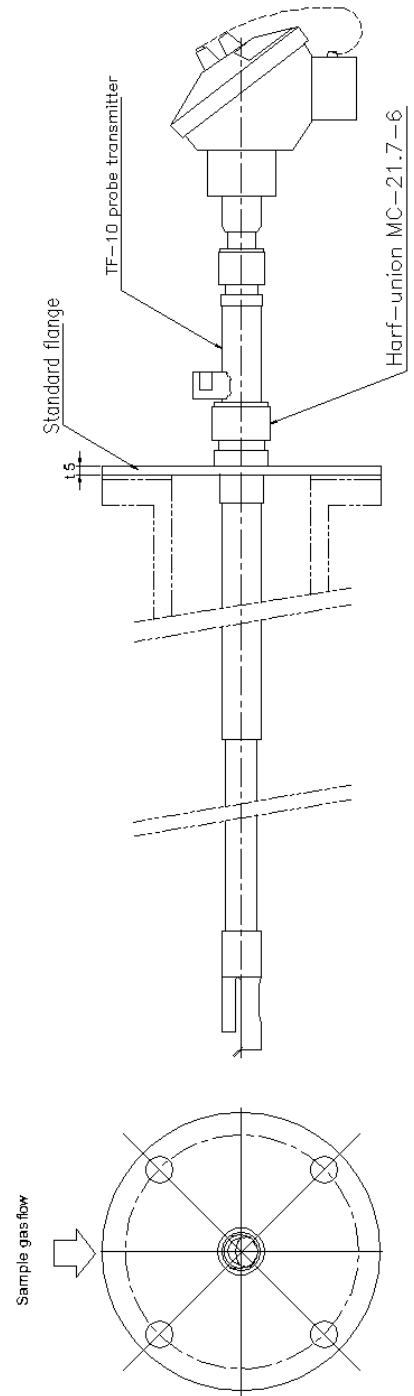

Flange with dust-proof guide pipe

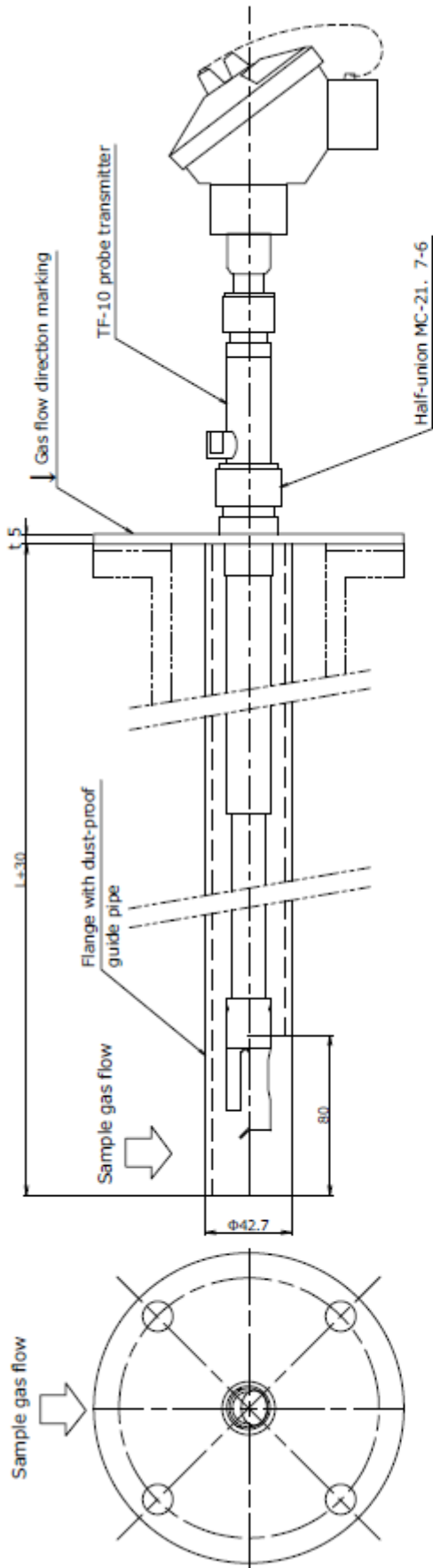

Flange with 1.5m-standard guide pipe

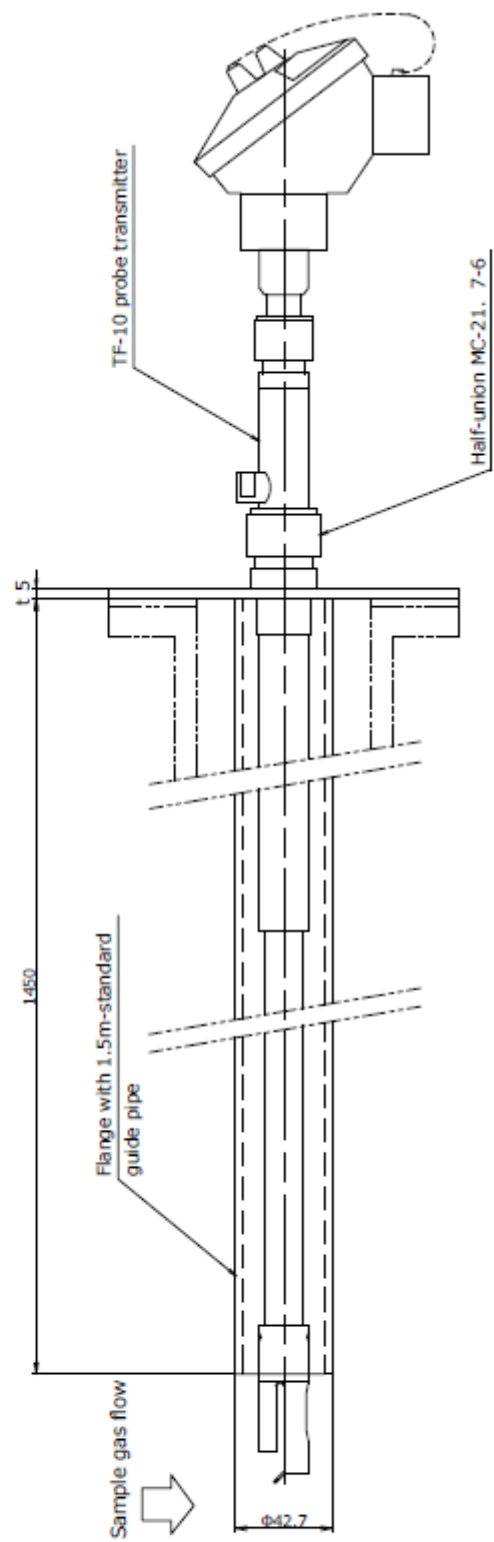

Filter unit(KX-331022)

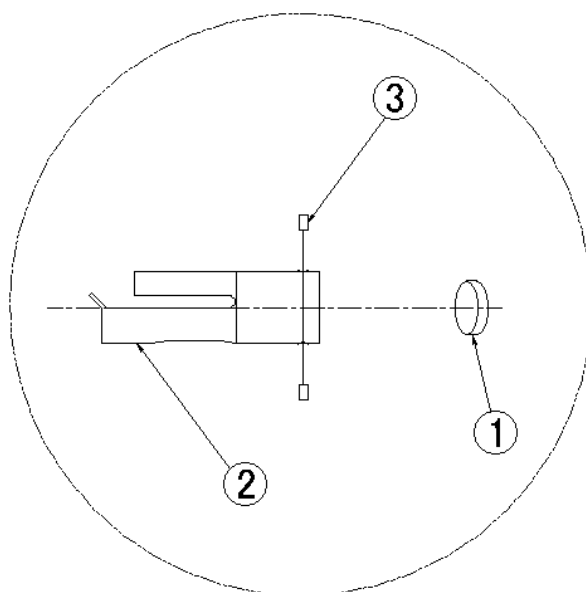

No.	品名	品番
1	HD ball filter	KX-391019
2	Filter cover	KX-391018
3	Hexagon socket head set screw	HG3M3L3SSUS316

Filter unit(KX-331023)

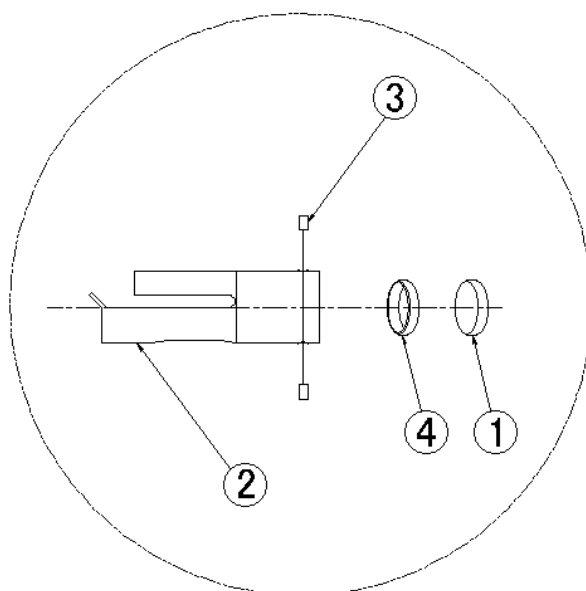

No.	品名	品番
1	Sintered wire mesh filter	P0.5D19
2	Filter cover	KX-391018
3	Hexagon socket head set screw	HG3M3L3SSUS316
4	spacer	KX-331018-SP

Sensor unit with terminal block

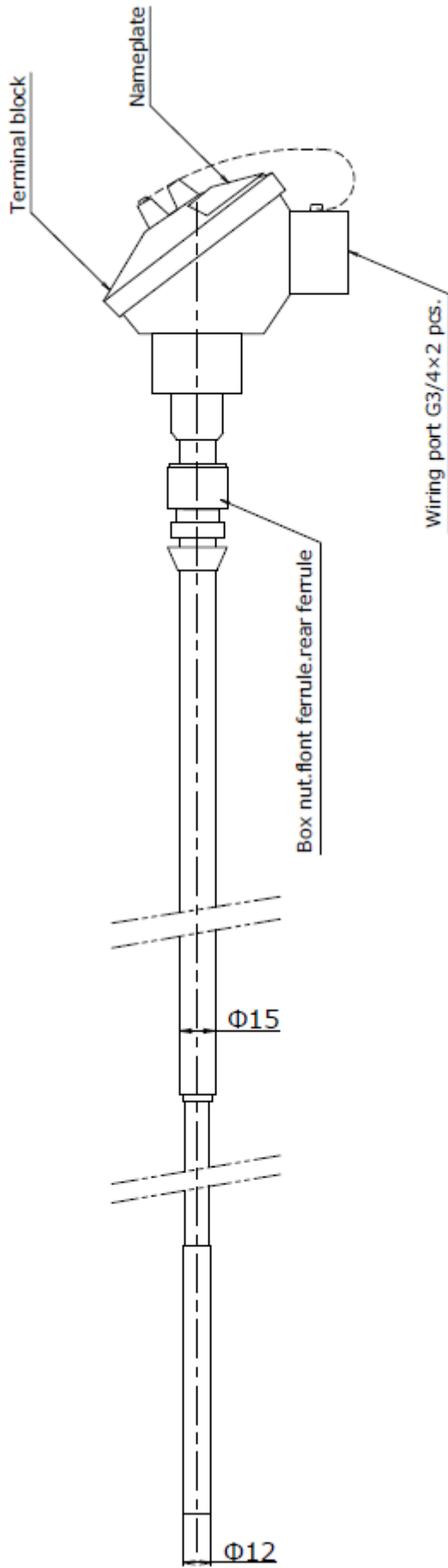

Sensor unit

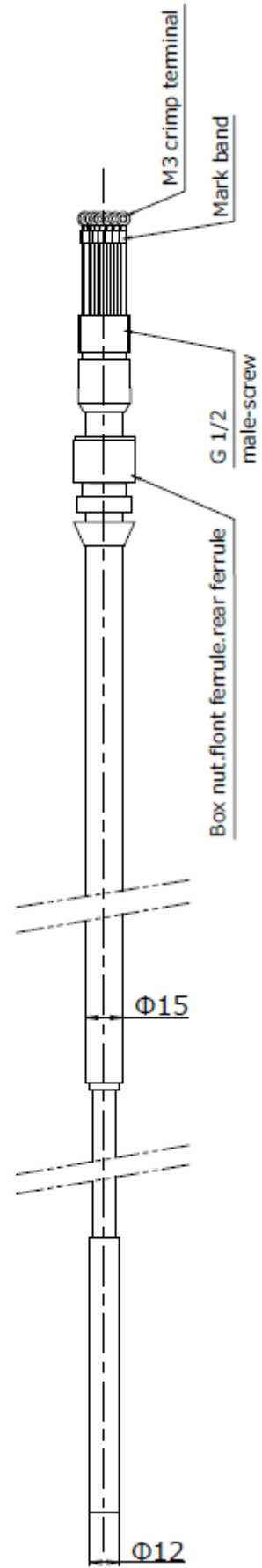

2. After unpacking of unit

2.1 Checking of accessories

List of product units and accessories

Name	Part No.	Q'ty	Remarks
TF-10 probe transmitter	KX-331022-A ** (- *)	1	(- *) : with Pressure correction coefficient
HD ball filter	KX-391019	1	Accessory
Hexagon socket head stop screw	HG3M3S3LSUS316	2	Accessory
Mori-coat 1000	KS-185352-6	1	Accessory
Hexagon bar spanner	1.5	1	Accessory
Flange *	May vary depending on the specification.	1	
Hexagon bolt	May vary depending on the flange size.	May vary depending on the flange size.	Accessory
Hexagon nut	May vary depending on the flange size.		Accessory
Flat washer	May vary depending on the flange size.		Accessory
Spring washer	May vary depending on the flange size.		Accessory
Flange packing	May vary depending on the flange size.	1	Accessory

The above table shows quantities for one set of units.

* Either the standard flange or flange with dust-proof guide pipe is to be delivered.

For details, see the final drawing of the oxygen analyzer.

2.2 Temporary storage of product



When temporarily storing the product, take care for the following:

- It is desirable to protect the product with styrene or similar in the box for storage.
- Store it at the place not directly exposed to sunlight.
- Store it at the surrounding temperature of -10 to 50°C with the minimal temperature variation.
- Store it at the place with minimal moisture and dust.
- Store it at the place not exposed to rain water.
- Store it at the place with minimal mechanical vibration.
- Store it at the place free of corrosive and dangerous gases.

3. Installation

3.1 Installation conditions



This analyzer is a precision unit. To safely and correctly operate this unit, always take the following conditions into consideration to determine an optimal installation place.

The unit must be installed in a place where;

- It is not exposed to the high radiation heat.
- The electromagnetic field does not affect it.
- The humidity and dust are minimized.
- A variation in voltage is minimized.
- A vibration in power supply frequency is minimized.
- The ambient temperature is $-10 - 50^{\circ}\text{C}$. (It is not exposed to the direct sunlight.)
- The following requirements for operating environment must be satisfied.

Probe transmitter	Installation place	Indoor/outdoor
	Ambient temperature ($^{\circ}\text{C}$)	-10 – 80
	Ambient humidity (% RH)	90 or less
	Installation posture	Horizontal – vertical downward

* The ambient temperature of the pump air type unit is $0 - 40^{\circ}\text{C}$.

- Corrosive gas does not exist.
- The number of installation flange vibrations shall be 100 Hz or less and the vibration amplitude shall be 0.5G or less.

(The vibration amplitude shall be 0.2G or less if the probe length is 1500 mm or 1000 mm and the horizontal mounting with the guide pipe is used.)

If the unit is installed in a place where the vibration level of the installation flange exceeds the above level, the customer must take appropriate measures so that the vibration is not applied to the probe transmitter directly.

- The resistance of the wiring between the probe transmitter and receiver shall be $5\ \Omega$ or less in the go and back way.

[
 For two CVVS 1.25sq-4c cables, the maximum length is 150 m or less.
 For two CVVS 0.9sq-4c cables, the maximum length is 120 m or less.
]

3.2 Installation procedures

Cautions for installation



- This analyzer is a precision unit. When installing this unit, do not apply excessive impact and/or load to it.
- This unit may be broken easily. Do not hit this unit when installing it.

(1) Installation of flange

- ① Install the flange with the dust-proof guide pipe so that the covering part faces toward the upstream side of the sample gas flow as shown in the Fig. below.
(The standard flange and flange with 1.5m-standard guide pipe have no orientations.)
- ② The mounting posture should be in a range of vertical downward to horizontal.
- ③ Install the flange packing so that it does not deviate.
- ④ Always tighten the hexagon bolts and nuts evenly.

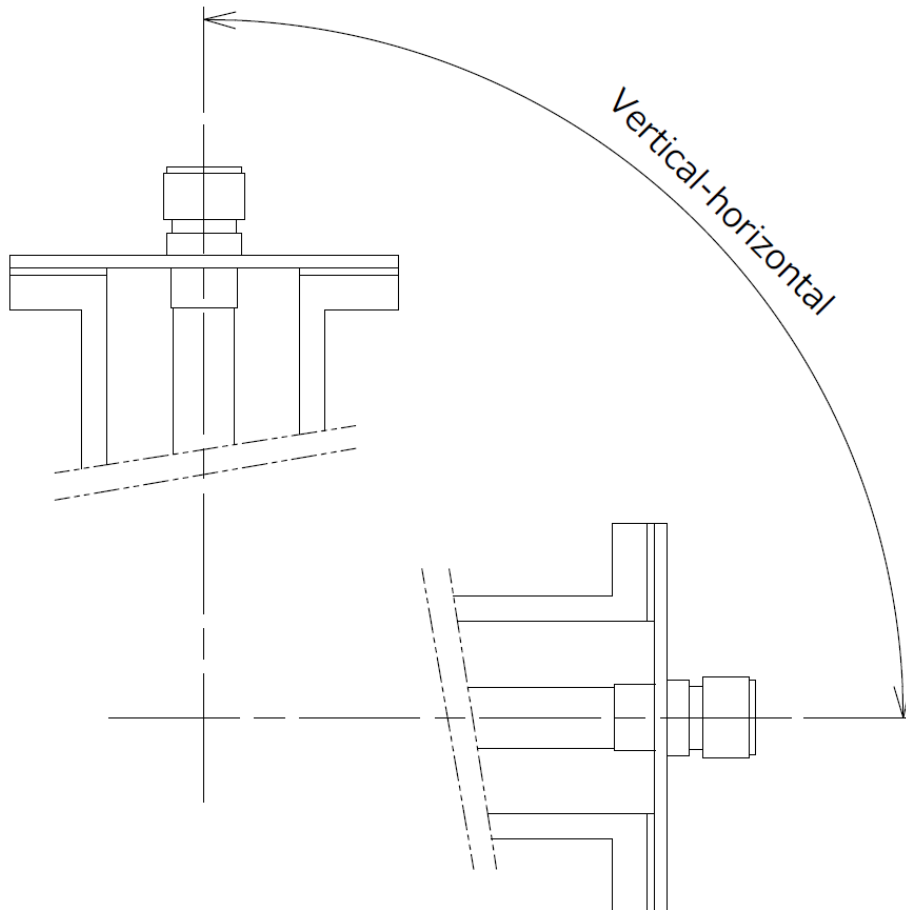

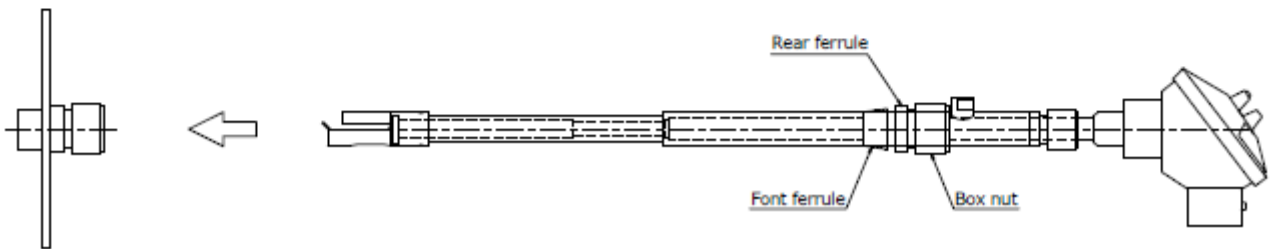
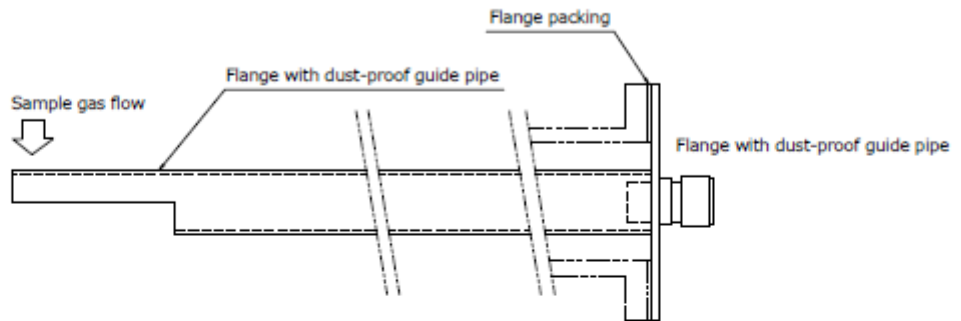
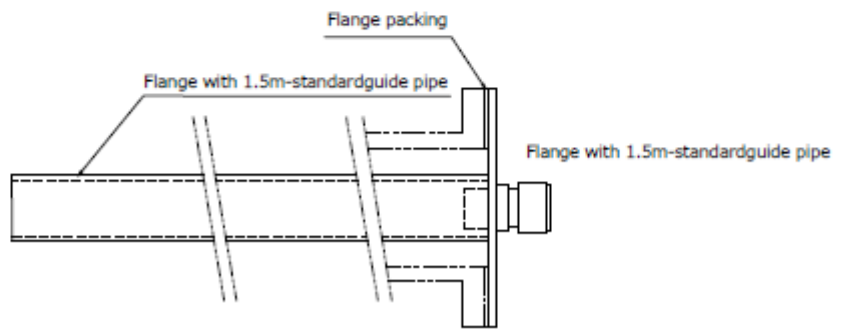
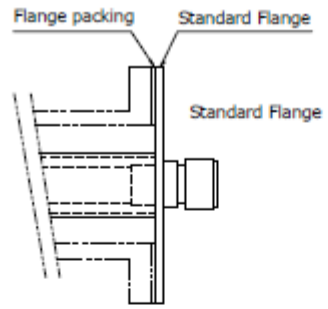

(2) Installation of probe transmitter

① Remove the box nut of the half-union MC-21.7-6, rear ferrule, and front ferrule from the flange, and then mount them on the probe transmitter.
(Pay special attention to their mounting orientations.)

② Gradually insert the probe transmitter so that the calibration gas inlet faces the upstream side of the sample gas.

First, insert the filter cover of the probe transmitter into the hole in the half-union of the flange.

If the probe transmitter is inserted slantwise, it cannot be inserted correctly.

At this time, if the probe transmitter is inserted forcibly, this may cause the probe transmitter to break.

③ When the filter cover is inserted, gradually insert the probe transmitter until the box nut is in contact with the calibration gas inlet.

④ Set the box nut, rear ferrule, and front ferrule, and then tighten them temporarily.

⑤ The insertion length of the probe transmitter becomes the maximum level when the box nut of the half-union is in contact with the calibration gas inlet of the probe.

This insertion length can be changed as shown in the Fig. below.

(If the probe transmitter is equipped with the guide pipe, the insertion length cannot be changed.)

Before retightening the box nut, always adjust the insertion length.

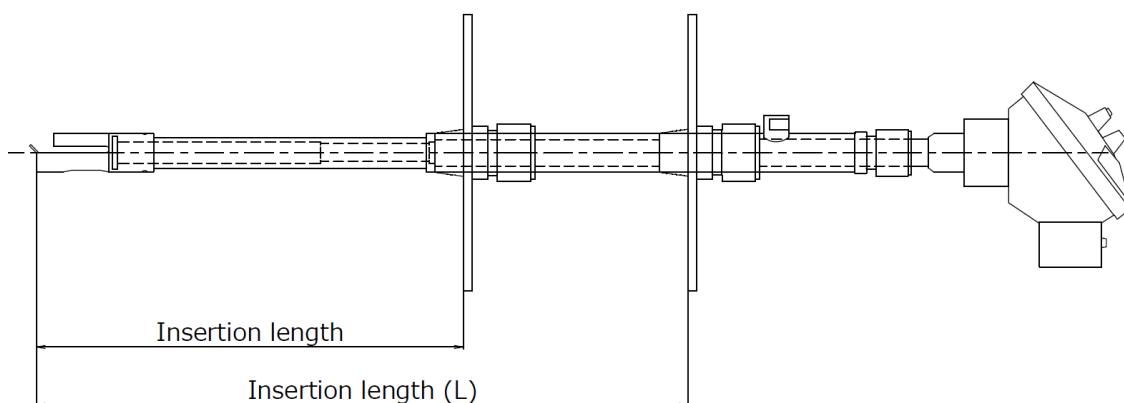

Insertion length adjustable range

Length (L) is 500.:	Insertion length is 250 – 500 mm.	} The above data is applied only when using the standard flange.
Length (L) is 1000.:	Insertion length is 750 – 1000 mm.	
Length (L) is 1500.:	Insertion length is 1000 – 1500 mm.	

⑥ Tighten the box nut in the following manner.

<To newly tighten the box nut>

- Lightly tighten the box nut with a spanner until the probe is no longer turned by hand. This point is determined as start point.
- Tighten the box nut $1 \frac{1}{4}$ rotations from this start point.

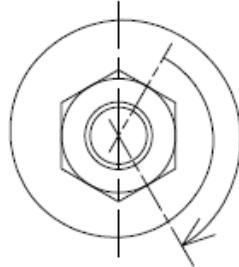

$1 \frac{1}{4}$ rotations

- After plant operation has been started, retighten the box nut further about $\frac{1}{8}$ rotation.

<To retighten the box nut>

- Lightly tighten the box nut with a spanner until the box nut is no longer moved. From this position, retighten the box nut further about $\frac{1}{8}$ rotation.

(3)Warmer installation work after installation of the probe transmitter

Warmer installation work shall be performed after installation of the probe transmitter

The guide pipe and flange warmer shall be installed as illustrated below to prevent corrosion at lower temperatures due to condensation in the guide pipe or at the flange

To permit removal of the probe transmitter, the warmer at the flange section is desirably detachable.

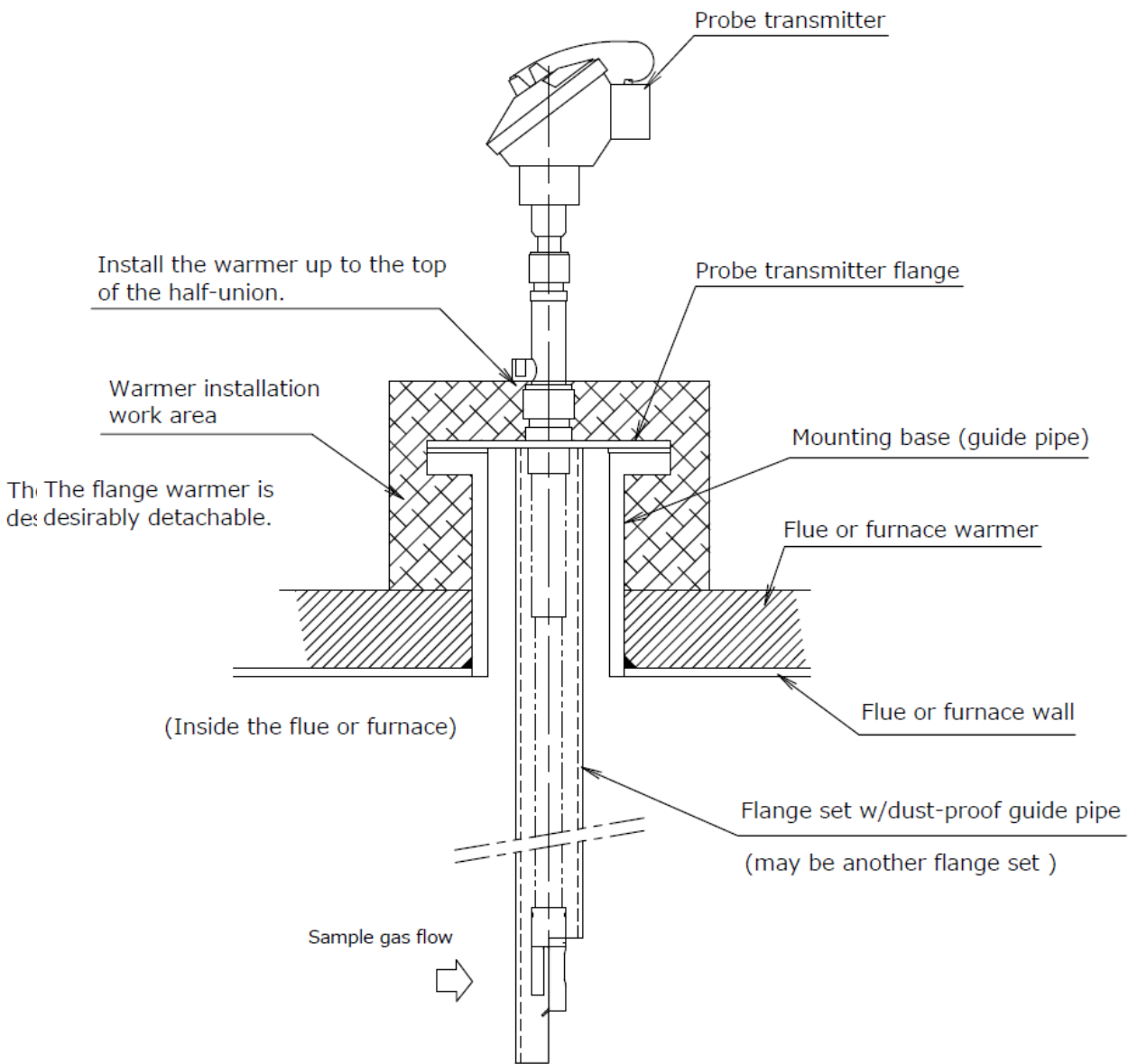

3.3 Piping and wiring procedures

(1) Piping procedures

Carry out the piping work between the calibration gas outlet and calibration gas inlet of the probe transmitter.

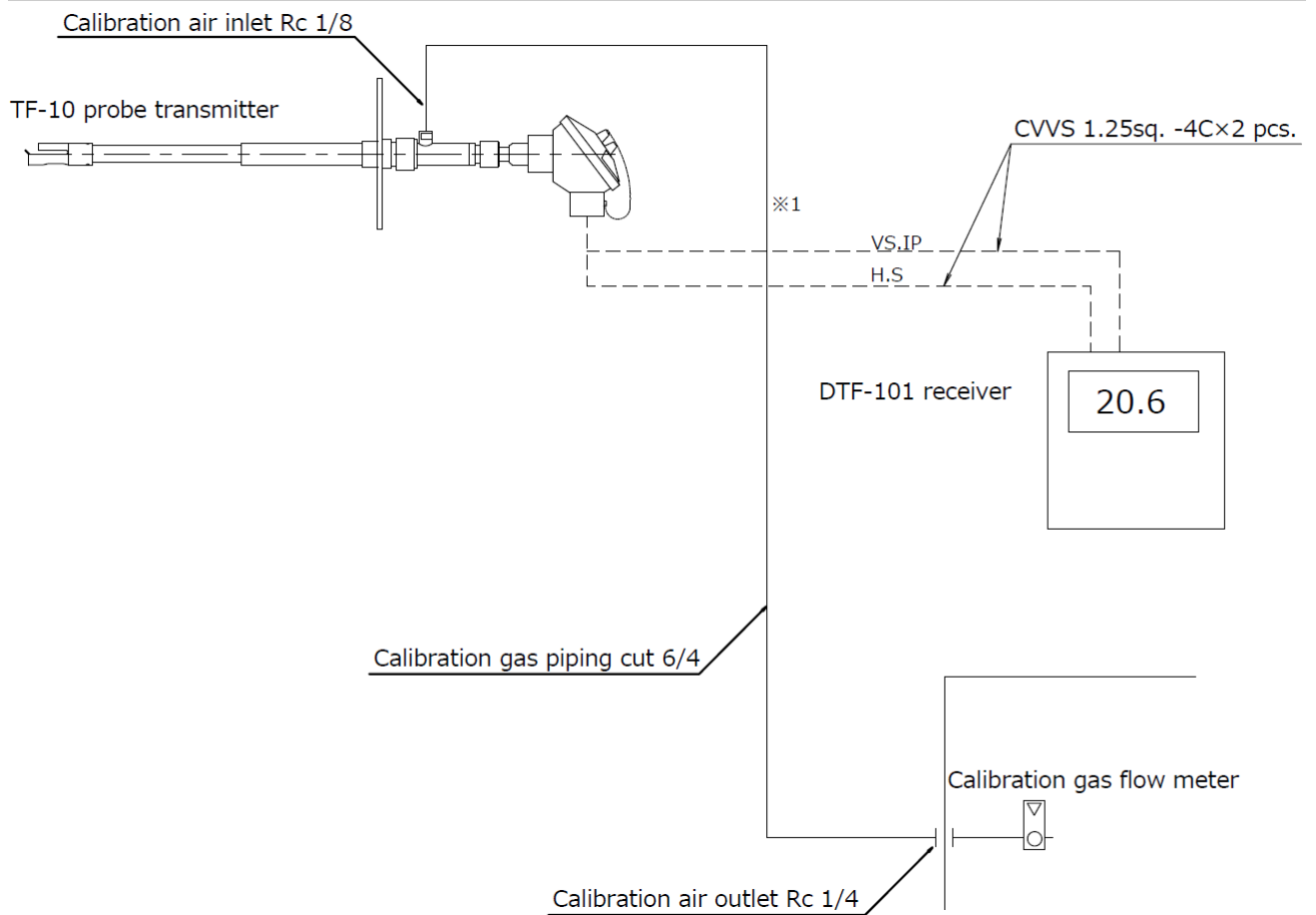

*1: A flexible conduit is used for this portion (probe length + 1 m) to easily inspect and pull out the probe.

(2) Wiring procedures

Carry out the wiring work between the probe transmitter and receiver, between the receiver and instrument room, and between the receiver and calibration unit.

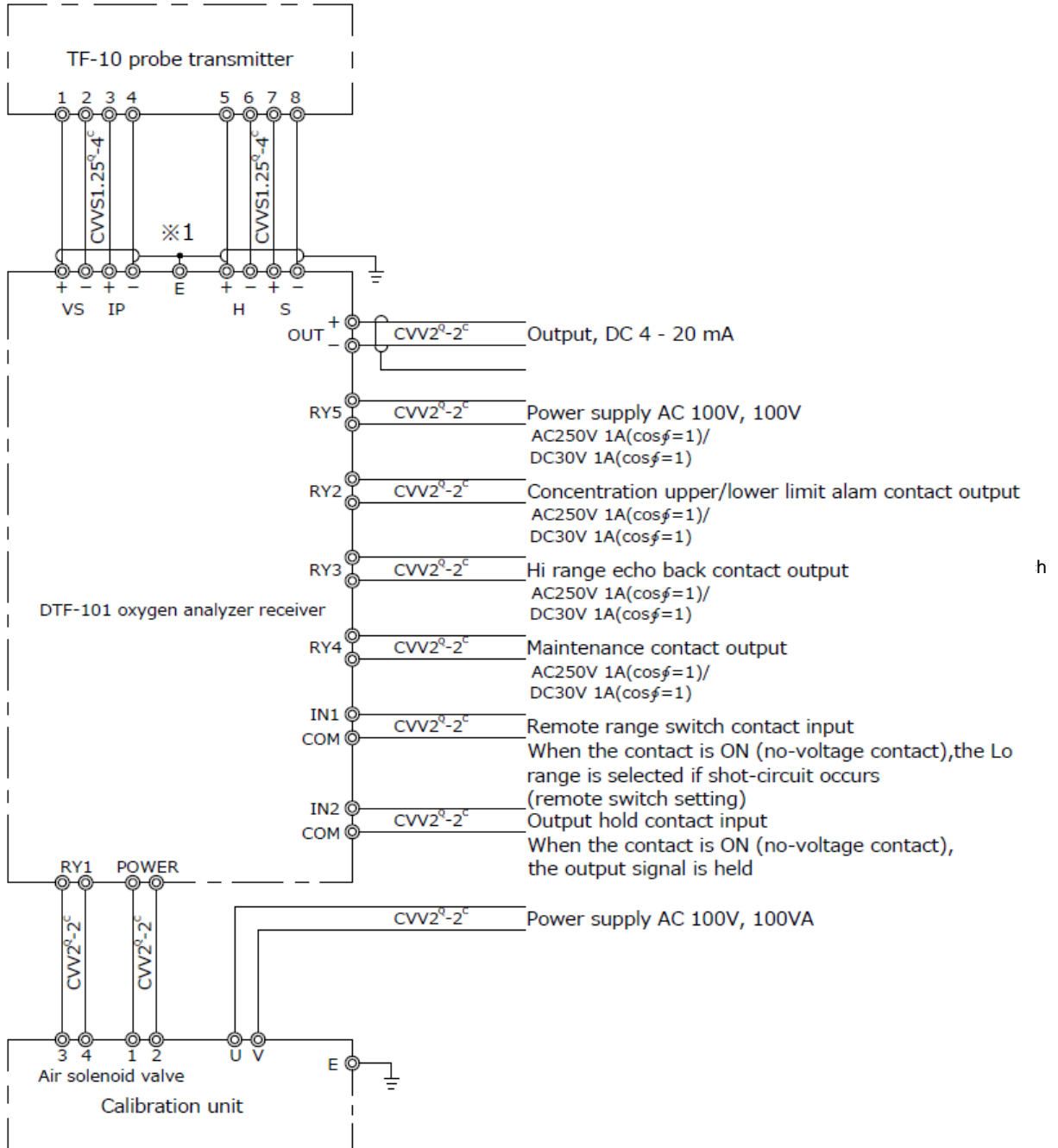

*1: 3-core wires are used for the wiring work. Always install the grounding plate on the grounding terminal of the receiver, and connect the grounding lines to it.

(3) Wiring on probe transmitter

— 20 —

Carry out the cable wiring through the wiring port (2-G 3/4) under the terminal block.

Run two 4-core cables one-by-one through the wiring port.

Additionally, take appropriate dust-proof and drip-proof measures during installation work.

All the terminal screws are M4 screws.

Caution) Do not touch the M3 terminal for the sensor unit.

Terminal screws are M4 screws.

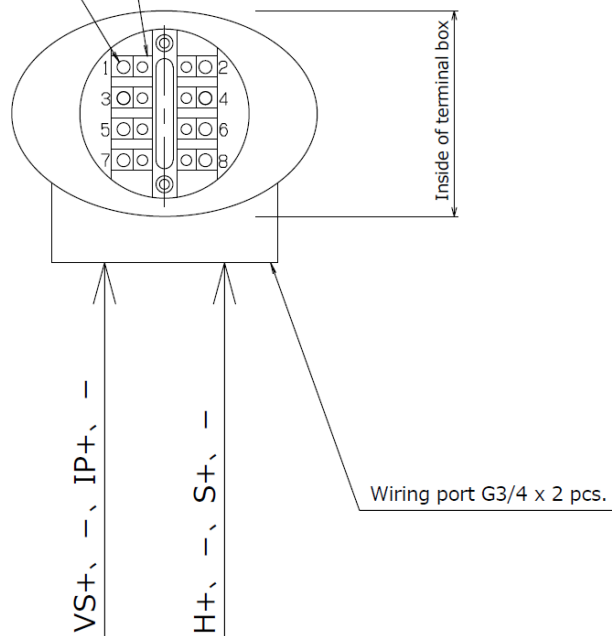

Caution) Process the end of the cable sheath close to the wiring port and put only the lead wire in the terminal box.

Caution) Carefully carry out the wiring work so that the conductors are not short-circuited in the terminal box.

3.4 Inspection after installation



Proper wiring from the transmitter of Model TF-10 probe transmitter to the receiver . If power is supplied to the wrong wiring, it will cause a sensor breakage or other serious trouble.

In order to prevent trouble which results from wrong wiring, check the wiring by the following procedure with the air selected as the measured gas when turning on the power supply for the first time for test operation and adjustment.

After verifying that the power supply of the receiver is off, check the following.

(1) Heater wiring check (H+),(H-),(S+),(S-)

Check the followings after confirmed the receiver power is OFF.

- Resistance is measured at terminal block of the receiver between (H+), (H-) and between (S+),(S-).

Reference value : Heater resistance (2.5-4) Ω + lead wire resistance in transmitter (0.5-3) Ω
+ wiring cable resistance (0-5) Ω

- Resistance is measured at terminal block of the receiver between (H+), (H-), and between (S+), (S-).

Reference value : Lead wire resistance in transmitter (0.5-2) Ω + wiring cable resistance (0-5) Ω

(2) Signal Load Wiring Check(Vs+),(Vs-),(Ip+),(Ip-)

Turn the electrical power to ON by disconnecting the lead wires of (Ip+),(Ip-) at receiver terminal block. Warm-up of transmitter is complete in about 3 minutes, so the followings are measured at the lead wires disconnected at the receiver terminal board.



Take sufficient care to prevent the disconnected line from being short-circuited or grounded.

The EMF between (Vs+) and (Vs-) is measured.

Standard value: 0 to 150mV (Approx. 40mV)

The EMF between (Ip+) and (Ip-) is measured.

Standard value: 0 to 100mV(Approx. 0mV)

(3) Heater polarity check

Followings are measured at terminal block of the receiver.

Voltage between (H-) and (H+) Standard value: 5 to 13V(approx. 10V)

Voltage between (S-) and (S+) Standard value: 5 to 13V(approx. 10V)

Potential of (H+) and (S+) must be the same.

Potential of (H-) and (H+) must be the same.

(4) Signal wiring polarity check

Turn the electrical power to OFF and connect the lead wires(Ip+) and (Ip-) disconnection in paragraph(2) on the receiver side

Then turn the electrical power to ON and the followings are measured at transmitter side after elapsed 3 minutes.

Voltage between (Vs-) and (Vs+): Standard value: 300 to 600mV(approx. 450mV)

Voltage between (Ip-) and (Ip+): Standard value: 0.3 to 1.5V(approx. 1V)

(5) Maintenance inspections and wiring checks during the sensor replacements will be easier when the cable marking bands are attached on the transmitter and receiver cables at this time after completed the wiring checks.

Note: The standard values indicated in paragraph(1) through(4) above are those when the sensor is at an initial condition. Because that value may change with the use, therefore, the wiring checks must be made using the sensor in an initial condition.

Check Sheet during initial installation(Refer to paragraph (1) to (4) on the previous pages for details of the checks.)

	Check items		Standard value	Check 1 ()	Check 2 ()
(1)	Heater + lead wire + cable resistance	H+/H-	2.5- 9Ω		
		S+/S-	2.5- 9Ω		
	Lead wire + cable resistance	H+/S+	5Ω or less		
		H-/S-	5Ω or less		
(2)	Sensor signal	Vs-/Vs+	Approx. 40mV		
(3)	Heater wiring Polarity	H+/H-	Approx. 10V		
		S+/S-	Approx. 10V		
		H+/H-	Approx. 10V		
		H-/H+	Approx. 10V		
(4)	Sensor signal Wiring polarity	Vs-/Vs+	Approx. 450mV		
		Ip-/Ip+	Approx. 1V		



This column is reserved for a convenient use during checks.

4. Maintenance

4.1 Cautions for maintenance



WARNING

- (1) If the sensor unit is removed while the plant is being operated, the hot sample gas may spout out from the furnace. Therefore, do not remove the sensor unit during operation. If removal of the sensor unit is absolutely required, always observe the following cautions.



CAUTION

- (2) Carefully observe the following cautions when installing or removing the probe transmitter.
 - ① Always wear heat-resistant gloves since parts close to the mounting seat are hot.
 - ② The hot sample gas and/or soot and dust may spout out from the opening of the mounting seat. Do not get access to the opening.
 - ③ The gas may also spout out from the calibration gas piping ports. Before installing or removing the probe transmitter, attach stop plugs to the piping ports. Restore the piping to its previous state immediately after the probe transmitter has been installed.
 - ④ The probe transmitter and sensor unit are hot. Always wear heat-resistant gloves to prevent burning hazards.
- (3) Always carefully install and/or remove the probe transmitter and sensor unit. Failure to do so may cause the ceramic parts inside the unit to break.
- (4) Do not turn the terminal block with the sensor unit secured. The lead wires inside the sensor may be twisted, resulting in faulty wiring.
- (5) Always apply the screw burning prevention agent (Mori coat 1000, Dow-coating) supplied with the unit to the hexagon socket set screws securing the filter cover.

4.2 Maintenance and inspection items



The following table shows the maintenance and inspection items necessary to ensure correct functions and precise measurement.

Before starting the maintenance and inspection work, always fully understand the contents stated in the table.

Unit name	Inspection part and item	Inspection criteria and method	Recommended frequency	Remarks
Probe transmitter	Air calibration	Perform the air calibration using the manual, semi-auto, and auto calibration procedures. (For details, see the air calibration procedures.)	Once a month. (One week after the unit has been installed newly.)	
	Sensor output inspection	Check CAL. DATE monitor after the air calibration has been performed. If AIR IP \geq 10mA, AIR IP \leq 2mA, or AIR VP \geq 3.0V, replace the sensor.	Once every 3 – 6 months	This data can be checked using the DISPLAY SELECT during air calibration.
	Sensor drift amount inspection	Check CAL. DATE monitor after the air calibration has been performed. If A. DRIFT \geq 0.5%, check that the calibration is performed correctly. When necessary, perform the calibration again.	Once every 3 – 6 months	
	Sample gas response time inspection	Measure the 90% response time between turning OFF of the solenoid valve and changing of the indication value to the sample gas value after the air calibration has been performed. If T90 \geq 3 min., replace the HD ball filter.	Once every 3 – 6 months	T90 may vary depending on the sample gas flow rate. Normally, T90 is approximately 90 sec. at 2 m/s. If a negative pressure is applied inside the furnace, the air remaining inside the piping may affect T90.
Calibration unit	Calibration air flow meter	1 L/min. (1 – 3 L/min.)	Once every 3 – 6 months	If no guide pipes are provided and the gas flow rate is 20 m/s, 3L/min. is required. Normally, set this value to 1L/min.

4.3 Troubleshooting

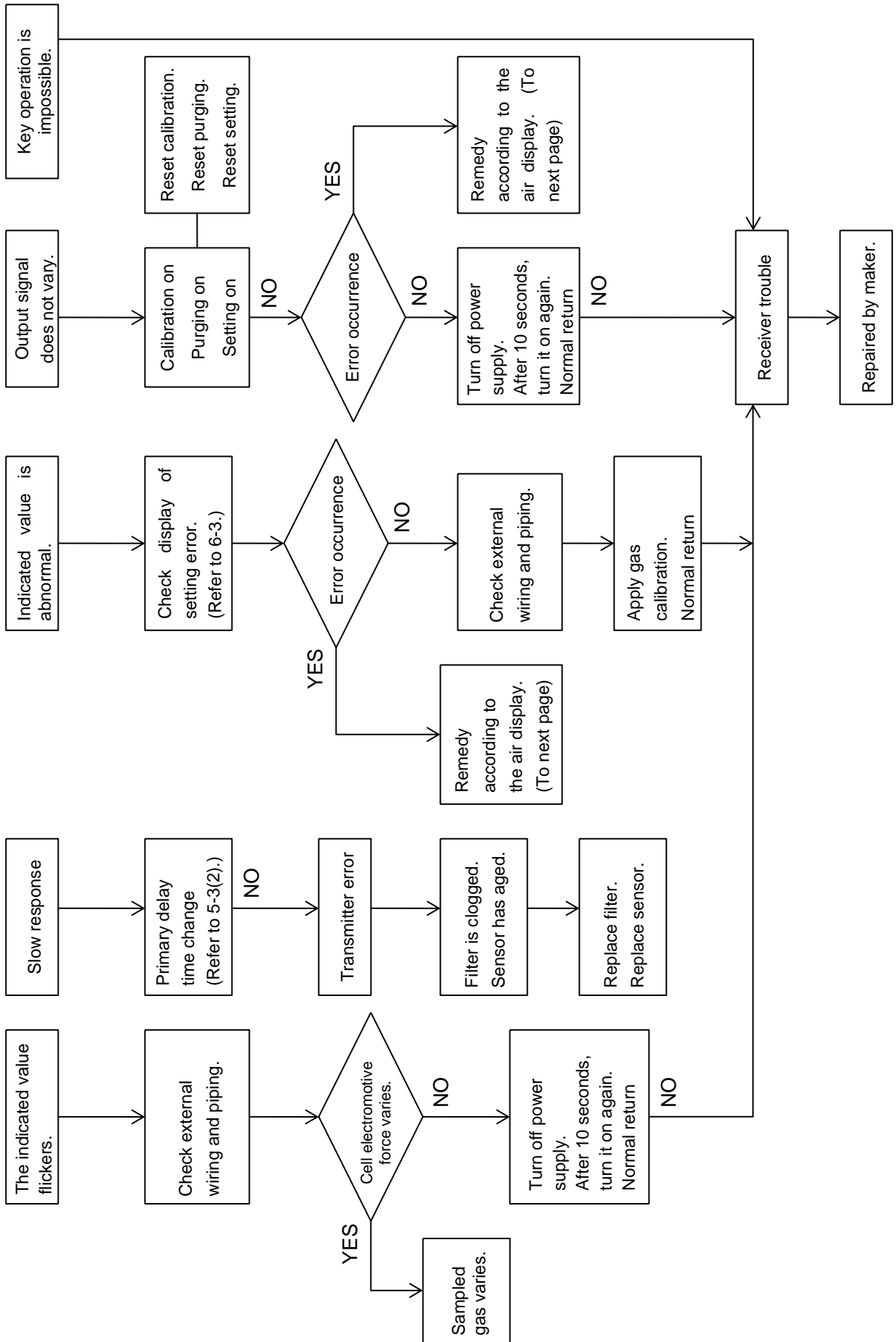

4.4 Replacement parts

① Spare and consumable parts

Part name	Part No.	Recommended replacement frequency	Remarks
Flange packing	T1995-*	Every 1 year	This part may vary depending on the flange size.
HD ball filter	KX-391019	Every 1 year	Replace this part if the sample gas response is delayed.
Filter cover	KX-391018	Every 2 years	The replacement frequency may vary depending on operating conditions.
Hexagon socket head set screw	HG3M3L3SSU316	Every 2 years	The replacement frequency may vary depending on operating conditions.

② Other replacement parts

Name	Part No.	Replacement criteria	Remarks
Sensor unit with terminal block	KX-731027-A* * (- *)	<ul style="list-style-type: none"> • Replace this part if the sensor error occurs. • Replace this part if it is corroded or damaged excessively. • Replace this part regularly once every 2 – 3 years as normal maintenance routine. 	** shows the length. (- *) : with Pressure correction coefficient
Sensor unit (This unit is not equipped with the terminal block. Therefore, the terminal block needs to be mounted from the old unit to a new unit.)	KX-731024-A* *	<ul style="list-style-type: none"> • Replace this part if the sensor error occurs. • Replace this part if it is corroded or damaged excessively. • Replace this part regularly once every 2 – 3 years as normal maintenance routine. 	** shows the length.
Terminal head (Terminal block)	KX-731019	<ul style="list-style-type: none"> • Replace this part if it is corroded or damaged excessively. 	
Guide probe	KX-391020-**	<ul style="list-style-type: none"> • Replace this part if it is corroded or damaged excessively. 	** shows the length.
Standard flange	KX-391017-*	<ul style="list-style-type: none"> • Replace this part if it is corroded or damaged excessively. 	** shows the size.
Flange with 1.5m-standard guide pipe	KX-391026-*	<ul style="list-style-type: none"> • Replace this part if it is corroded or damaged excessively. 	* shows the size.
Flange with dust-proof guide pipe	KX-391025-***	<ul style="list-style-type: none"> • Replace this part if it is corroded or damaged excessively. 	*** shows the length and size.

4.5 Replacement of parts

(1) Replacement of glass tube fuse

Removal: Turn the fuse holder counterclockwise 1/4 rotation while keeping it pressed.

Mounting: After the fuse has been replaced with a new one, turn the fuse holder clockwise 1/4 rotation while keeping it pressed.

(2) Removal of probe transmitter

① Turn OFF the power to the receiver.

② Disconnect the wiring and piping from the terminal block of the probe transmitter.

③ Loosen the box nut of the flange half-union MC-21.7-6 and gradually pull out the probe transmitter backward. (If the probe transmitter is pulled out slantwise, the filter cover cannot be pulled out. Always pull out the probe transmitter straight.)



Since the probe transmitter is hot, always carefully perform the above work to prevent burn hazards.

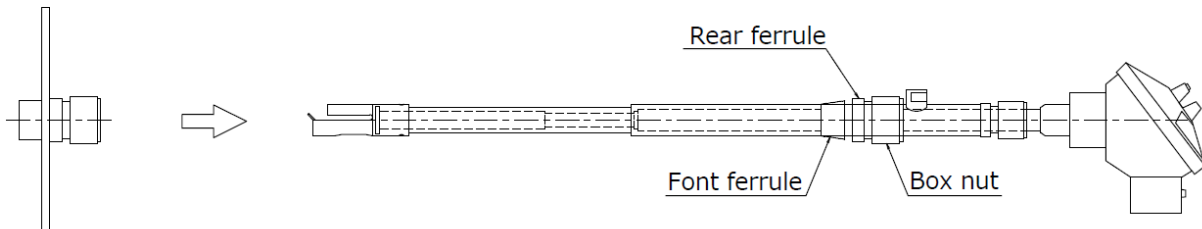
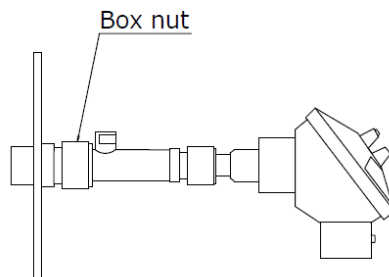

(3) Mounting of probe transmitter

(To install a new probe transmitter, see the section, Installation. This section describes how to mount the probe transmitter, which has been removed for the maintenance work.)

- ① Gradually insert the probe transmitter with the calibration gas inlet and filter cover opening faced toward the upstream of the sample gas.

(First, insert the filter cover of the probe transmitter into the hole in the half-union of the flange. If the probe transmitter is inserted slantwise, it cannot be inserted correctly. At this time, if the probe transmitter is inserted forcibly, this may cause the probe transmitter to break.)

- ② When the filter cover is inserted, gradually insert the probe transmitter by the previous insertion distance (to a part where the ferrule of the half-union is tightened.)
- ③ Tighten the box nut and reconnect the wiring and piping.

(4) Removal of 【 A 】 , filter cover, and hexagon socket head set screws

- ① Remove the probe transmitter. (See the steps above.)
- ② Prepare the hexagon bar spanner (width across flat: 1.5) and Mori-coat 1000 (KS-185352-6) supplied with the unit.
- ③ Remove the upper and lower hexagon socket head set screws with the hexagon bar spanner. Move the filter cover to the top. The filter cover and 【 A 】 can then be removed.

The 【 A 】 cover is sandwiched only by the guide probe and filter cover.

(5) Mounting of 【 A 】 , filter cover, and hexagon socket head set screws

- ① Prepare the hexagon bar spanner (width across flat: 1.5) and Mori-coat 1000 (KS-185352-6) supplied with the unit.
- ② Put the 【 A 】 inside the filter cover and insert it to the top of the guide probe while carefully checking the orientation of the filter cover.
 - If the 【 A 】 rotates and deviates in the filter cover, the filter cover cannot be mounted. To avoid such troubles, insert the top of the filter cover with it faced downward slightly. This ensures easy mounting without deviation of the 【 A 】 .
 - For the orientation of the filter cover, make the orientation of the probe calibration gas inlet matched with the opening of the filter cover (sample gas upstream side).

【 A 】 : HD ball filter (KX-331022-A)

or

Sintered wire mesh filter , spacer (KX-331023-A)

- ③ Set the hexagon bar spanner on the hexagon socket head set screw, apply the Mori-coat 1000 to the M3 screw thread part of the hexagon socket head screw sufficiently, and assemble it to the probe.
- Always apply the Mori-coat 1000. (This may prevent the screw threads from being burnt.)
 - If the hexagon bar spanner is tightened excessively, the spanner edge may be rounded. Always carefully observe this caution.

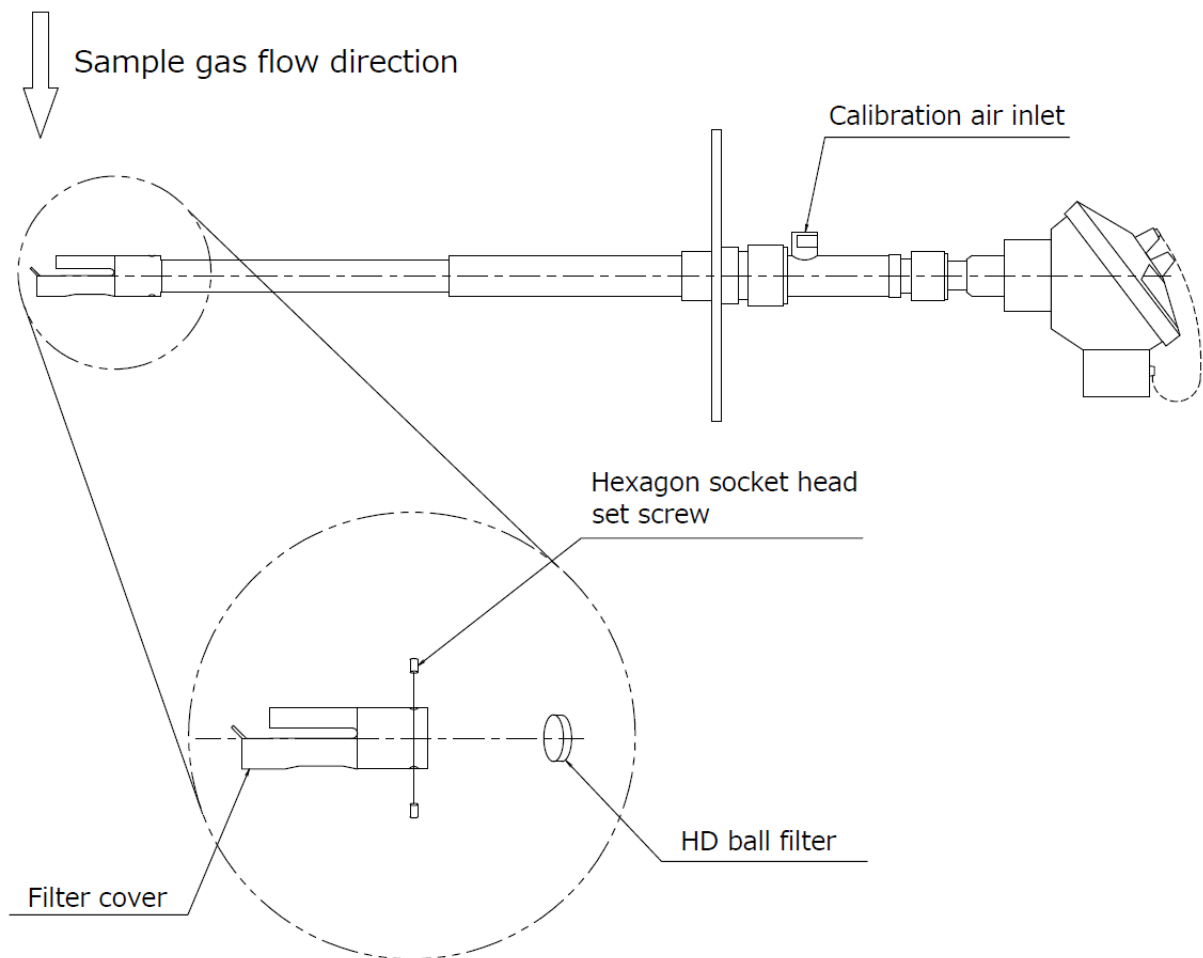

(6) Removal of sensor

- ① Turn OFF the power to the receiver.
- ② Disconnect the wiring from the terminal block of the sensor unit.
- ③ Loosen the box nut of the half-union MC-15-4 of the sensor unit.
- ④ Put the spanner on the sensor unit part having a width across flat of 18 mm. By turning the spanner, gradually shift and pull out the sensor unit backward.

Do not turn the terminal block with the sensor unit secured. The lead wires inside the sensor may be twisted, causing the sensor to malfunction.

Always set the spanner on the part with a width across flat of 18 mm and carefully turn the spanner to pull out the sensor unit.



Since the probe transmitter is hot, always carefully perform the above work to prevent burn hazards.

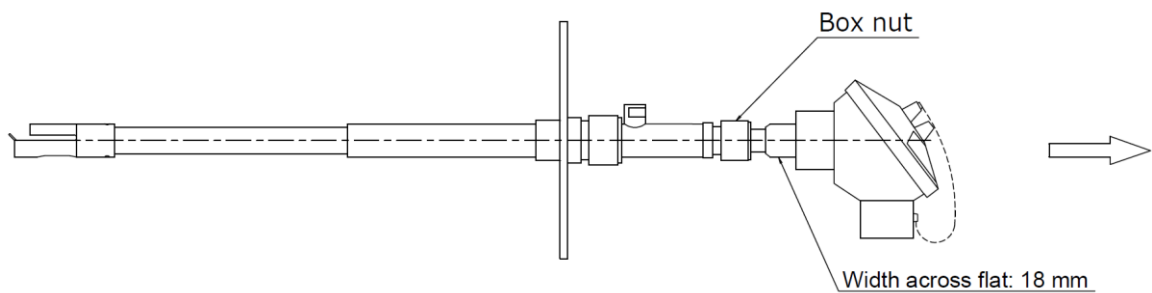

(7) Mounting of sensor unit

- ① Mount the front ferrule, rear ferrule, and box nut on the sensor unit while carefully checking their orientations.
- ② Gradually insert the top of the sensor unit into the hole in the half union MC-15-4 of the probe.
- ③ When the top of the sensor unit is inserted, gradually insert the sensor unit.
(Even though it is felt that the insertion is slightly hard when inserting the part located after the stepped part of the sensor unit, insert it forcibly.)
- ④ Insert the sensor unit until the stepped part of the sensor guide is in contact with the inner surface of the stepped part of the guide probe.
Both stepped parts are in contact with each other at the last of the insertion work. Insert the sensor unit in the insertion direction.
- ⑤ Tighten the box nut. (After the box nut has been tightened, the gap between the box nut and part with a width across flat of 18 mm becomes approximately 10 mm as shown in the Fig. below.)
- ⑥ Restore the wiring to the previous state.

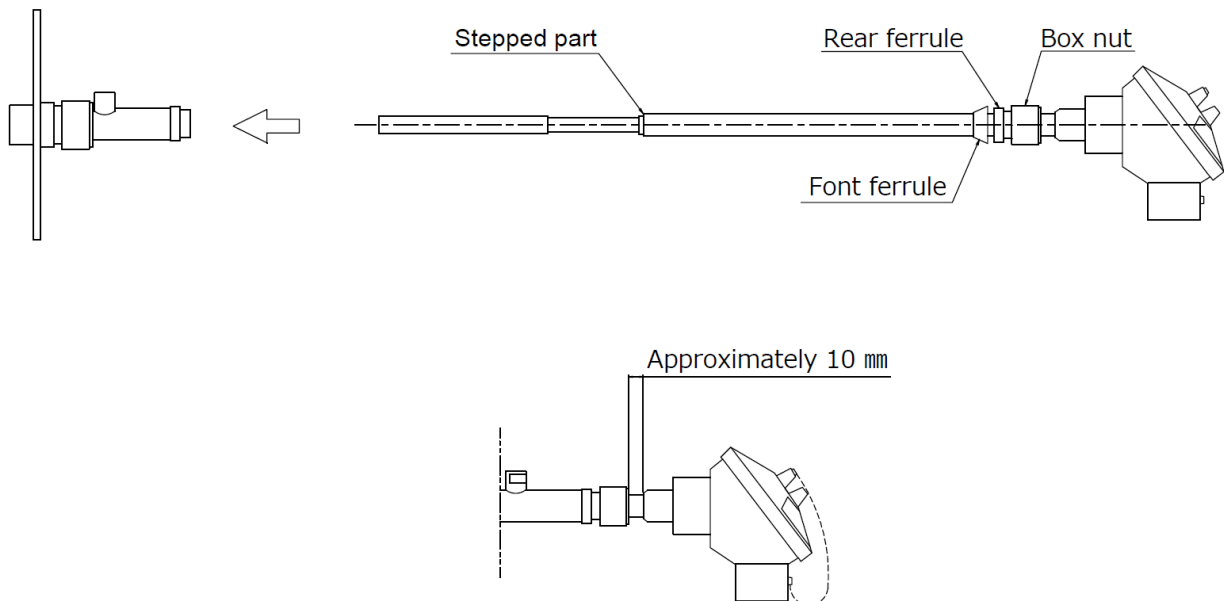

4.3 Start-up Operation

The basic operation procedure for starting the oxygen analyzer is shown below.

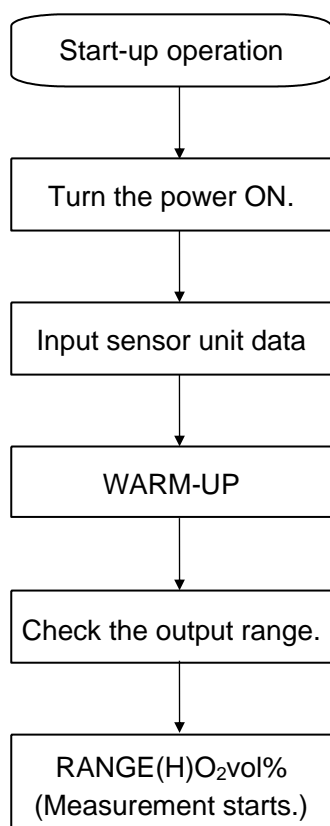

① Turn the power ON.

After the external power switch and the power switch inside the receiver are turned on, the receiver starts the count-down timer for warming the sensor (WARM-UP shown on LCD). After the set temperature has been reached, the measurement mode starts.

After the power has been turned ON, input RH0 (normal temperature heater resistance value) of the sensor unit using the DISPLAY SELECT key, and LIN (linearizer NO.) using the SENSOR PARAMETER key.

When pressure correction coefficient is available, enter $\beta 1$ (pressure correction coefficient) in addition to the above data using the PRESSURE SET key operation.

② Check the range (H/L) using the MODE key.

Operating the key on the receiver, check the output signal range.

4.4 Stopping Operation

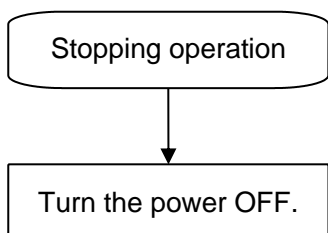

Before turning the receiver off, check that the inside of the transmitter and the sensor are in the air environment. Otherwise sensor deterioration will result.

Turn the power switch of the receiver off.



When inspecting the terminals of the analyzer or receiver or performing maintenance work accompanying disconnection of wiring, turn the external power switch (source power switch) off.

5. References

5.1 Standard specifications

1. Measuring Range : 0~10/0~25%O₂ Range (Wet base)

(The measurement range should be switched with the receiver key)

Calibration range : 0~25%O₂

2. Power Supply : AC100V±10% 50/60Hz

max.100VA

3. Output Signal : DC4~20mA (Isolated, max. loading resistance of 600Ω)

The output signal is hold (retained) if an error occurs or during calibration.

4. Calibration gas : Air one-point calibration (1~3L/min./1set)

5. Control Unit : pump air type (Instrument air is not required.)

Instrument air port installation type (Instrument air is required.)

Instrument air

Amount of Fine Powder : 0.1mg/Nm³ or less

Diameter of Fine Powder : 10 μm or less

Content of Impure Oil : 1ppm or less

Dew Point at Normal Air : -17°C or less

Pressure : 0.2~0.7Mpa

6. Probe Length : 500mm below Flange 1000mm below Flange 1500mm below Flange

7. Flange size : Considerable to JIS5K65AFF Considerable to JIS10K65AFF Others (Special)

8. Guide pipe : If the probe is 1500 mm long, the 1500 mm-standard guide pipe is provided.

If the dust amount exceeds 1g/Nm³, the guide pipe for large dust amount corresponding to the probe length is provided.

9. Stand : Not Supplied Supplied

10. Method of mount : Receiver ; Wall mount type Stand

Calibration Unit ; Wall mount type Stand

11. Installation

		<input type="checkbox"/> Standard	<input type="checkbox"/> Special
Transmitter	Place	<input type="checkbox"/> Indoor <input type="checkbox"/> Outdoor	
	Temperature °C	-10~80	
	Humidity %RH	max.90	
	Mounting attitude	Horizontal-Vertical downward direction.	
Receiver	Place	<input type="checkbox"/> Indoor <input type="checkbox"/> Outdoor	
	Temperature °C	-10~50	
	Humidity %RH	max.90	
Calibration Unit	Place	<input type="checkbox"/> Indoor <input type="checkbox"/> Outdoor	
	Temperature °C	-10~50 (0~40) ※	
	Humidity %RH	max.90	

※ (The allowable ambient temperature of the pump air type is 0 - 40°C)

12. Conditions of measuring gas

Waste gas after general combustion

Others

	<input type="checkbox"/> Standard	<input type="checkbox"/> Special	Your specification
Flow rate	20m/sec. or less	m/sec.	m/sec.
Pressure	±5kPa (Variation in draft is ±3 kPa.)	kPa	kPa
Temperature	max.550°C	°C	°C
Dust concentration	<input type="checkbox"/> 1g/m ³ N or less <input type="checkbox"/> 1~30g/m ³ N	g/m ³ N	g/m ³ N
O ₂	0~25%	%	%
CO	—	ppm	ppm
CO ₂	0~20%	%	%
H ₂ O	0~25%	%	%
SO _x	max.2000ppm	ppm	ppm
NO _x	max. 500ppm	ppm	ppm
HCl	max.1000ppm	ppm	ppm
N ₂	Bal.	%	%

Notes 1.If the SO_x and HCl concentrations are 500 ppm or more, the analyzer is determined as consumable one year after starting of operation.

(The material (SUS316) of the probe and flange are corroded at a low temperature.)

2.Components other than those stated above shall not be included. In particular, if corrosive and/or toxic components (F,Cl,Si,Pb,Zn,Sn,As, etc.) exist, the sensor may deteriorate in a short time. Never use this analyzer under such operating conditions.

13. Calibration method : Air one-point auto calibration (To make the manual calibration valid, it is necessary to change the receiver system settings.)
(The zero gas calibration is not required since the zero drift is not included in the measuring principle.)
14. Response time : Within 5 sec. However, if the probe is 1.5 m long, the response time is 7 sec. or less.
(The above response time is obtained from the 90%-response performance test when the gas is switched between the air and standard gas (approximately 4% O₂).)
15. Repeatability : $\pm 0.5\%$ F.S.
16. Linearity : $\pm 1.0\%$ F.S. (F.S.=25%)
 $\pm 2.0\%$ F.S. (F.S.=5,10%)
17. Span drift : $\pm 2.0\%$ F.S./month (F.S.=25%, AIR point)
However, the span drift is $\pm 2.0\%$ F.S./week for one month after operation has been started.
18. Zero drift : $\pm 0.1\%$ O₂/year (N₂ point)
19. Warming-up time : Approx.3 min.
20. Contact inputs : Remote range switch, remote output hold,
remote auto calibration, etc. 1a \times 5
(To change the settings, it is necessary to change the receiver system settings.)
21. Contact outputs : (1) Self-diagnosis error, power shut-down, 1b \times 1
(2) Air solenoid valve drive, concentration upper/lower limit alarm,
Hi range echo back, maintenance, 1a \times 4
(To change the settings, it is necessary to change the receiver system settings.)
22. Sampling method : Direct duct insertion method (Principle : Zirconia 2-cell pump method)
23. Wiring between transmitter and receiver :
The wiring resistance shall be 5Ω or less in both in and out directions.
- | | |
|-----------------------------|-------------------|
| CVVS 1.25 sq.-4c \times 2 | max.150 m or less |
| CVVS 0.9 sq.-4c \times 2 | max.120 m or less |
- Piping : Control copper pipe cut $\phi 6/4$
(Wiring and piping materials shall be prepared by the customer.)

The contents of this manual are subject to change without notice for improvement.



For inquiries regarding product handling, please contact us or our distributors.
Inquiry form URL : <https://www.energyys.co.jp/english/inq/all.php>
ENERGY SUPPORT CORPORATION
1, Aza Kamikobarii, Inuyama, Aichi 484-8505 Japan

